



**Microprocessor based  
timer/counter housed  
in the industrial  
standard CYCL-FLEX®  
case**



5

ELECTRONIC

The CX300 is a microprocessor based timer/counter housed in a standard 15 terminal CYCL-FLEX® plug-in case which allows easy removal for programming changes and replacement. Time or count operation, time range, and the type of start input switch operation are programmed with 7 miniature rocker switches located inside the unit housing.

The front panel of the CX300 is a sealed membrane keypad which provides excellent protection for most industrial environments. The time or count setpoint is entered using the increment and decrement keys for each digit position. The SET and ENT keys provide access to the setpoint, as well as to the front panel programmable software functions. These programmable functions control the pulse output length, setpoint to zero or zero to setpoint cycle progress indication, and count input scale factor. The software programming functions are indicated by prompts to help the user program these functions without the need for written instructions.

- Keypad lock function allows viewing of setpoint, but does not allow unauthorized changes
- 4 1/2 digit (19999) liquid crystal display - .5 inch high digits
- Annunciators (right of the display) flash to indicate timing or counting
- Two form C instantaneous contacts and two form C programmed contacts
- Five time ranges from 19.999 sec. to 199 hr.: 59 min.
- Three count rate input rate speeds are programmable with a max. count display of 19999 - can be extended via count input scale factor
- 24, 120, or 240 VAC operations
- Count input available for 120 volt AC or low voltage AC/DC operations
- When programmed as timer, count input circuit serves as time inhibit (without resetting the unit)
- Non-volatile memory data retention

## SPECIFICATIONS

### Time/Count Ranges:

Sym.	Maximum Range	Minimum Setting	Count Rate
1	19999 Cts.	1 Ct.	4000/Sec. 12-50 VDC Count Input
2	19999 Cts.	1 Ct.	500/Min. AC or DC
3	19999 Cts.	1 Ct.	5000/Min. AC or DC
4	199.99 Sec.	.01 Sec.	
5	1999.9 Sec.	.1 Sec.	
6	19.999 Sec.	.001 Sec.	
7	199 Min.: 59 Sec.	1 Sec.	
8	199 Hr.: 59 Min.	1 Min.	

**Operating Voltage/Frequency:** A6 - 120 VAC, 50/60 Hz  
B6 - 240 VAC, 50/60 Hz  
Z6 - 24 VAC, 50/60 Hz

**Time Inhibit/Count Line Terminals B & C:**  
CX311/CX341 - 12-50 VDC or 20-28 VAC, 50/60 Hz  
CX312/CX342 - 120 VAC, 50/60 Hz or 120 VDC

**Setting Accuracy:** Time:  $\pm 0.1\%$  or 50 ms, whichever is larger (0° to 60°C)  
Count: 100%

**Repeat Accuracy:**  
Time:  $\pm 0.1\%$  or 35 ms, whichever is larger (0° to 60°C)  
Count: 100%

**Reset Time:** 30 ms following voltage removal from simulated clutch input (CR1)

**Power on Response:** 300 ms max. after voltage applied to terminal 11

**Operating Temperature:** +32° to +140°F (0° to +60°C)

**Output Rating:** Relay: 10 amp (resistive), 120 VAC  
Mechanical Life: 20 million operations  
Electrical Life: contingent upon controlled load  
Solid State: 1 amp, 0-264 VAC, VDC

**Vibration:** Unit function is unaffected by 2.5G sinusoidal vibration magnitude in both directions of the perpendicular mounting axes imposed from 10 to 100 Hz

**Static Discharge:** Unit function is unaffected by a constant 3600 volt peak, 60 Hz discharge applied to the grounded front plate at a relative humidity of less than 25%

**Approvals:** UL Recognition E96337  
CSA Certification LR26861

## OUTPUT OPERATING MODES

### ON-Delay Operation

The contacts are energized at the end of the timing/counting cycle and remain energized until the unit is reset.

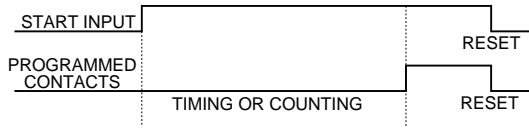

### Interval Operation

The contacts are energized during the timing/counting cycle and then shut off at the end of the cycle.

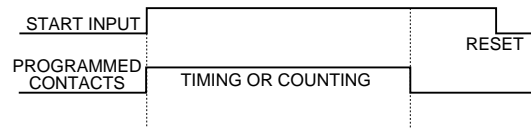

### Pulse Output Operation

The contacts are energized at the end of the timing/counting cycle for a pulse which is user programmable. See **Front Panel Feature Programming** instructions for details on how to program the pulse length..

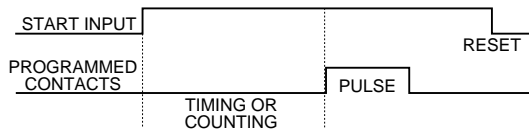

### Pulse and Repeat Operation

The contacts are energized at the end of the timing/counting cycle for a pulse which is user programmable. At the same time that the cycle is completed and the pulse output begins, the timing/counting cycle resets and begins again. This repeat operation continues as long as the start circuit is energized.

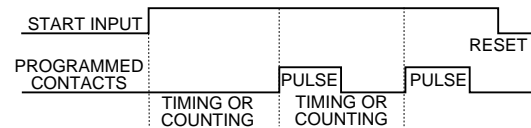

## MOUNTING

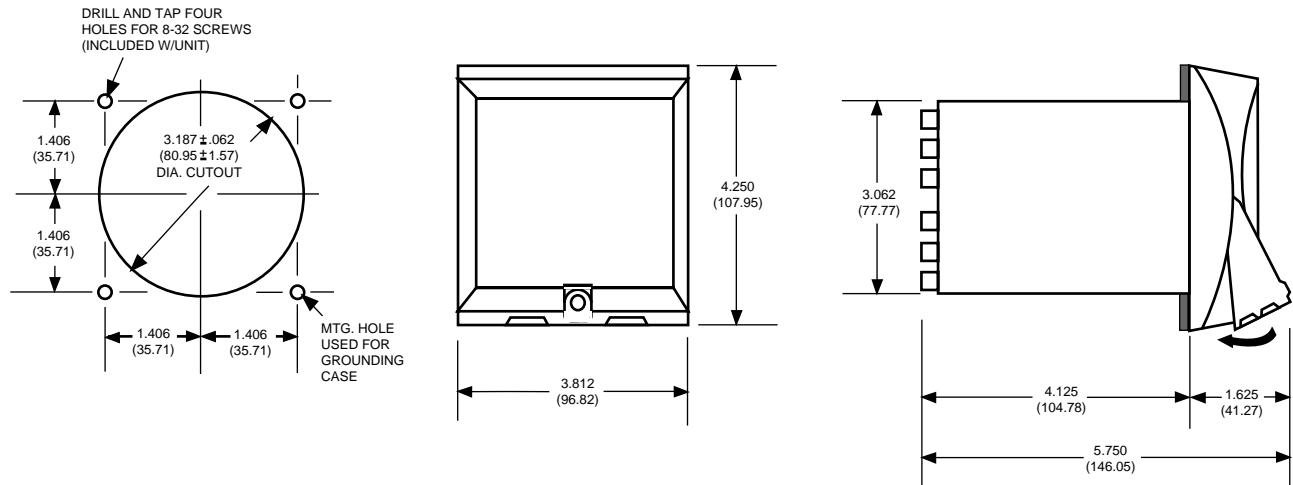

## ENCLOSURES

Model No.	NEMA Class	Description
HN308	1	Surface Mtg. with terminal block
HN364	1	Surface Mtg. without terminal block
HN370	1A	Dual unit cabinet less unit cases and toggle switch, with 9 terminal block

## ACCESSORIES

Model No.	Description
H-5331	Mounting Brackets 2 req'd per timer
HP50-31	One Hole Mounting Ring
HP50-131	CYCL-FLEX Water-Sealed Housing
HP50-133	Surface Mounting Adapter to use in place of brackets
PDM-534	1/4 DIN Adapter Plate

## ORDERING INFORMATION

### OUTPUT TYPE

Sym.	Description
1	10A DPDT Instantaneous 10 DPDT Delayed Relay Output
4	1A Solid State Output

### COUNT / INHIBIT INPUT VOLTAGE

Sym.	Description
1	12-50 VDC, 20-28 VAC, 50/60 Hz
2	120 VDC, 120 VAC, 50/60 Hz

### VOLTAGE & FREQUENCY

Sym.	Description
A6	120 VAC, 50/60 Hz
B6	240 VAC, 50/60 Hz
Z6	24 VAC, 50/60 Hz