



### Features

- 2440MHz to 2750MHz Operation
- Gain = 28dB Typical
- Gain Adjustment Range > 19dB
- ACPR = -64dBc Typ. at +12dBm P<sub>OUT</sub> (Dual Carrier WCDMA)
- Small, 7 mm x 7 mm, Multi-Chip Module

### Applications

- Cellular, 3G and 4G Infrastructure
- WiBro, WiMax, LTE
- Microwave Radio
- High Linearity Power Control

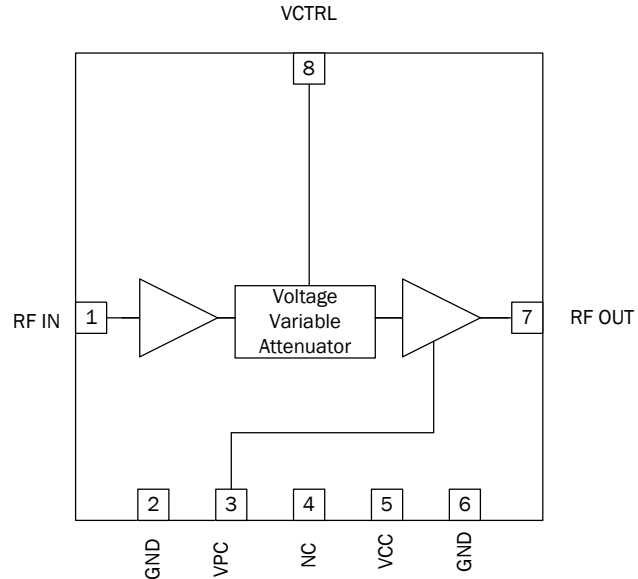

Functional Block Diagram

### Product Description

RFMD's RVA3007L is a fully integrated analog controlled variable gain amplifier featuring exceptional linearity over a greater than 19dB gain control range. This variable gain amplifier is controlled by a single 0V to 3.3V positive supply voltage. The RVA3007L is packaged in a small 7 mm x 7 mm leadless laminate MCM which contains solid thermal vias for ultra low thermal resistance. This module is internally matched to 50Ω and is easy to use with no external matching components required.

### Ordering Information

RVA3007LSQ	Sample bag with 25 pieces
RVA3007LSR	7" Sample reel with 100 pieces
RVA3007LTR7	7" Reel with 1500 pieces
RVA3007LTR13	13" Reel with 2500 pieces
RVA3007LPCK-410	2440MHz to 2750MHz PCBA with 5-piece sample bag

### Optimum Technology Matching® Applied

- |   |                                      |                                     |                                   |
|---|--------------------------------------|-------------------------------------|-----------------------------------|
| <input type="checkbox"/> GaAs HBT             | <input type="checkbox"/> SiGe BiCMOS | <input type="checkbox"/> GaAs pHEMT | <input type="checkbox"/> GaN HEMT |
| <input type="checkbox"/> GaAs MESFET          | <input type="checkbox"/> Si BiCMOS   | <input type="checkbox"/> Si CMOS    | <input type="checkbox"/> RF MEMS  |
| <input checked="" type="checkbox"/> InGaP HBT | <input type="checkbox"/> SiGe HBT    | <input type="checkbox"/> Si BJT     | <input type="checkbox"/> LDMOS    |

RF MICRO DEVICES®, RFMD®, Optimum Technology Matching®, Enabling Wireless Connectivity™, PowerStar®, POLARIS™ TOTAL RADIO™ and UltimateBlue™ are trademarks of RFMD, LLC. BLUETOOTH is a trademark owned by Bluetooth SIG, Inc., U.S.A. and licensed for use by RFMD. All other trade names, trademarks and registered trademarks are the property of their respective owners. ©2006, RF Micro Devices, Inc.

## Absolute Maximum Ratings

Parameter	Rating	Unit
Max Device Current	770	mA
Max Device Voltage	5.5	V
Max Control Line Voltage	6	V
Max RF Input Power*	12	dBm
Max Junction Temp (T <sub>j</sub> )	+150	°C
Max Storage Temp	+150	°C
Thermal Resistance (junction to backside of module)	14.8	°C/W
ESD	Class 1C (1000V min)	
Moisture Sensitivity Level	MSL3	

\*Load condition: Z<sub>L</sub> = 50Ω



**Caution!** ESD sensitive device.

Exceeding any one or a combination of the Absolute Maximum Rating conditions may cause permanent damage to the device. Extended application of Absolute Maximum Rating conditions to the device may reduce device reliability. Specified typical performance or functional operation of the device under Absolute Maximum Rating conditions is not implied.

The information in this publication is believed to be accurate and reliable. However, no responsibility is assumed by RF Micro Devices, Inc. ("RFMD") for its use, nor for any infringement of patents, or other rights of third parties, resulting from its use. No license is granted by implication or otherwise under any patent or patent rights of RFMD. RFMD reserves the right to change component circuitry, recommended application circuitry and specifications at any time without prior notice.



RoHS (Restriction of Hazardous Substances): Compliant per EU Directive 2002/95/EC.

Parameter	Specification			Unit	Condition
	Min.	Typ.	Max.		
Frequency	2440		2750	MHz	
Temperature Range	-40	25	+85	°C	Operating range
Gain	25	28	31	dB	Min attenuator setting
Nominal Operating Output Power		12		dBm	Operating power for ACPR rating
Output IP3	39	45		dBm	In high gain setting
P1dB	27	29.5		dBm	High gain setting
ACPR	-58	-64		dBc	Dual carrier WCDMA, 7.5dB CF at nominal operating power; over full attenuation range
Gain Flatness		0.2	0.4	dB	Over 50MHz BW
Gain Adjustment Range	19			dB	
Control Voltage Range	0		3.3	V	
Noise Figure		5.0	6.5	dB	Min attenuator setting
Impedance		50		Ω	
Input Return Loss	9	12		dB	Over attenuation range
Output Return Loss	11	18		dB	Over attenuation range
Supply Voltage	4.75	5.0	5.25	V	
Supply Current	300	410	550	mA	Max current is at -40 °C
Supply Current (VPC=0V)	65	85	100	mA	Output amplifier shutdown total current; VPC=0V

GAIN VS. CONTROL VOLTAGE VS. TEMPERATURE @ 2595 MHz

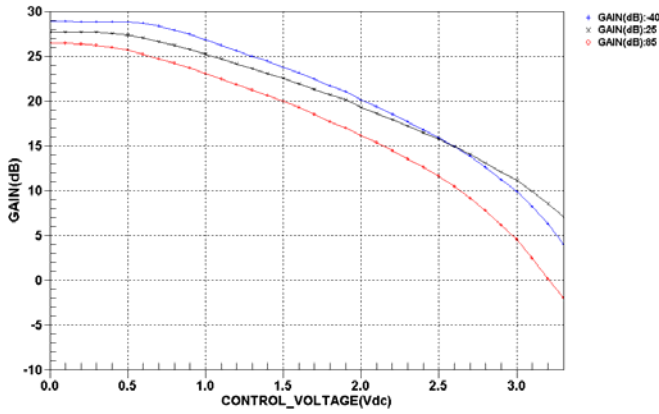

GAIN VS. FREQUENCY VS. CONTROL VOLTAGE

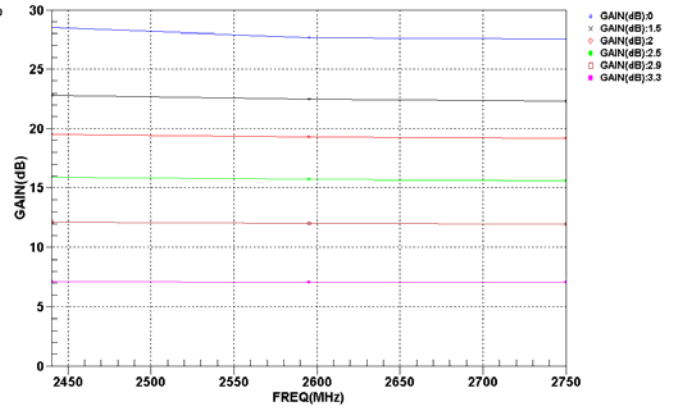

INPUT IP3 VS. CONTROL VOLTAGE VS. TEMPERATURE @ 2595 MHz

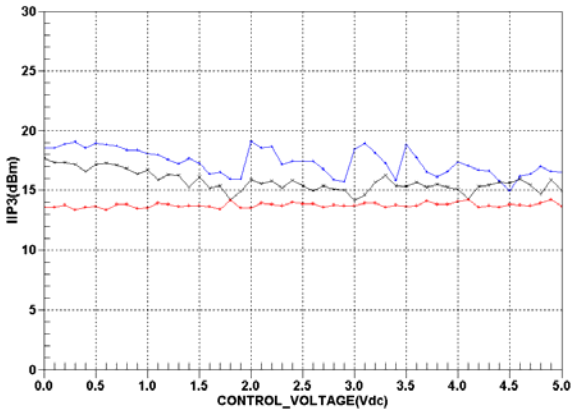

OUTPUT IP3 VS. CONTROL VOLTAGE VS. TEMPERATURE @ 2595 MHz

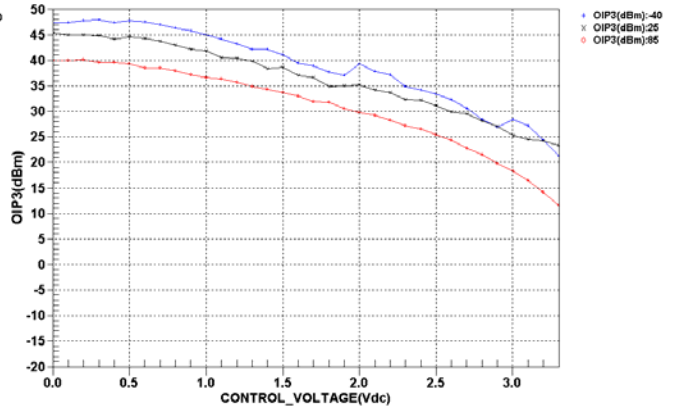

ATTENUATION VS. CONTROL VOLTAGE VS. TEMPERATURE @ 2595 MHz

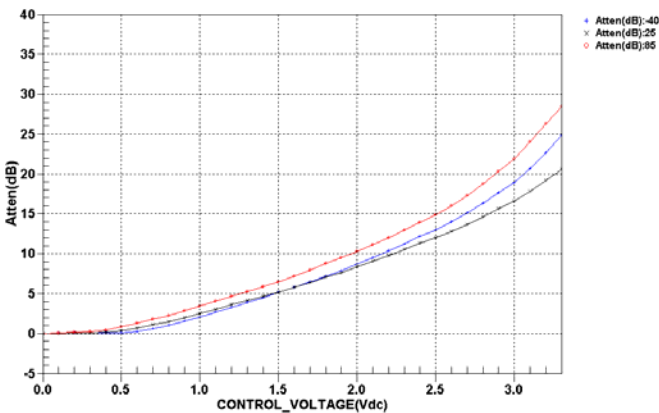

INPUT RETURN LOSS VS. FREQUENCY VS. CONTROL VOLTAGE

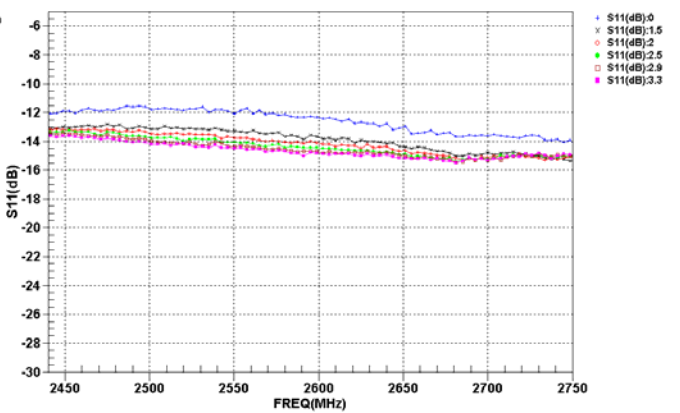

INPUT RETURN LOSS VS. CONTROL VOLTAGE VS. TEMPERATURE @ 2595 MHz

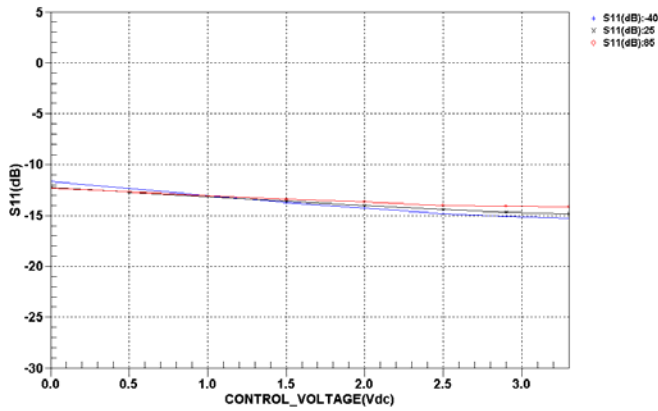

OUTPUT RETURN LOSS VS. FREQUENCY VS. CONTROL VOLTAGE

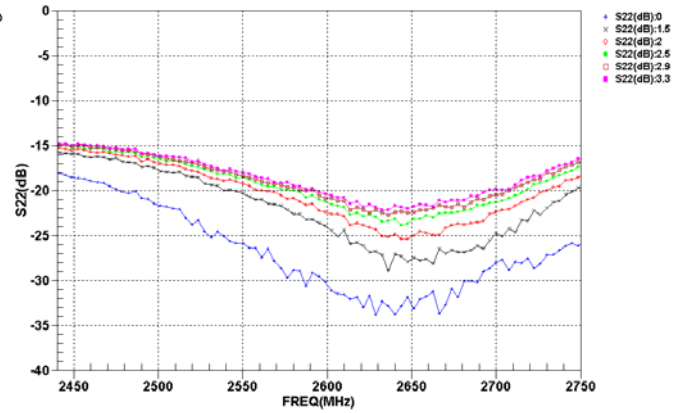

OUTPUT RETURN LOSS VS. CONTROL VOLTAGE VS. TEMPERATURE @ 2595 MHz

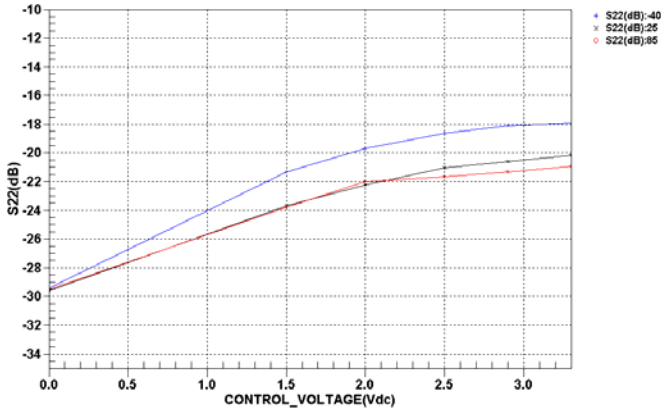

NOISE FIGURE VS. FREQUENCY VS. CONTROL VOLTAGE

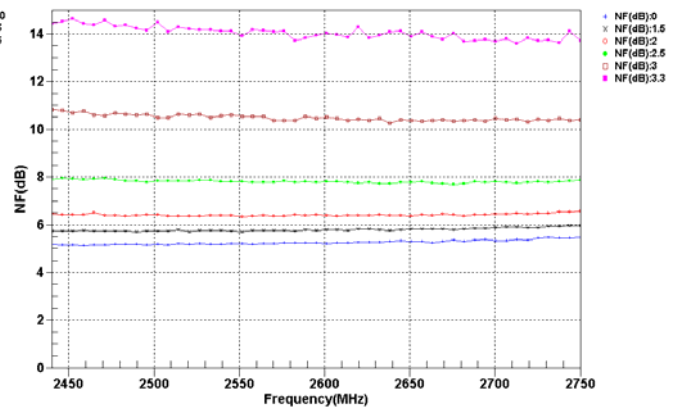

**Evaluation Board Schematic**

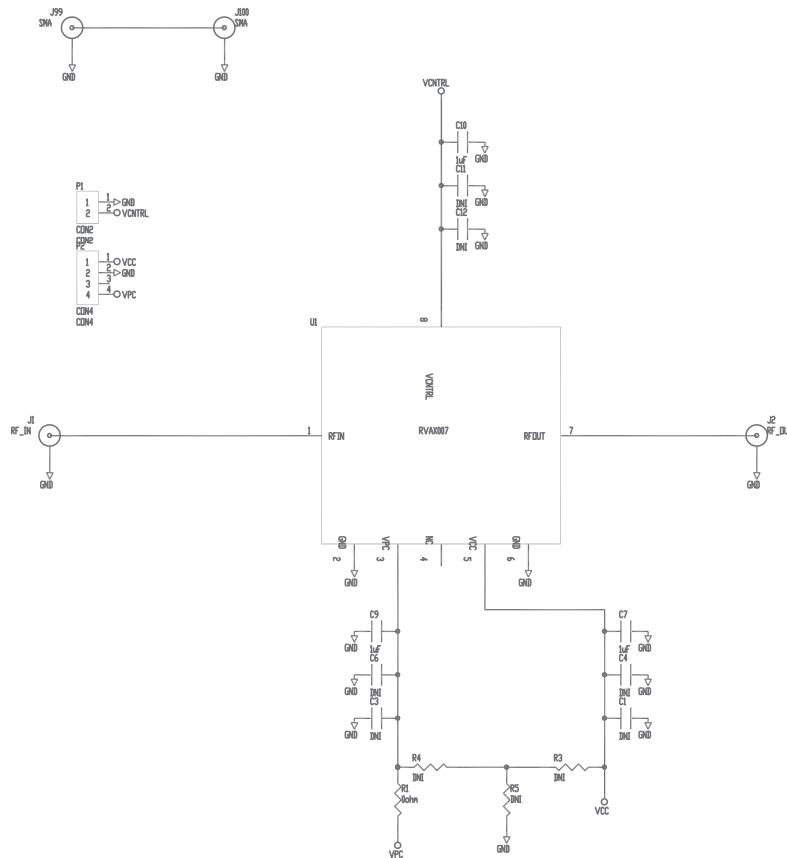

**Evaluation Board Bill of Materials (BOM)**

Description	Reference Designator	Manufacturer	Manufacturer's P/N
EVALUATION BOARD		DDI	RFVx007L410(A)
CAP, 1 $\mu$ F, 10%, 10V, X5R, 0402	C7, C9- C10	MURATA ELECTRONICS	GRM155R61A105KE15D
RES, 0 $\Omega$ , 0402	R1	KAMAYA, INC	RMC1/16SJPTH
CONN, SMA, END LAUNCH, UNIV, HYB MNT, FLT	J1- J2	HEILIND ELECTRONICS	PER MAT-21-1038
CONN, HDR, ST, PLRZD, 4-PIN, 0.100"	P2	ITW PANCON	MPSS100-4-C
CONN, HDR, ST, PLRZD, 2-PIN, 0.100"	P1	ITW PANCON	MPSS100-2-C
DNP	C1, C3-C4, C6, C11-C12, R3-R5		
RVA3007L MODULE	U1	RFMD	RVA3007L

## Pin Table and Description

Pin	Function	Description
1	RFIN	RF input pin. Internal DC block.
2	GND	Ground pin.
3	VPC	Power up/down control for 2nd stage amplifier. Apply $V_{CC}$ to power on 2nd stage amplifier. Apply 0V to disable 2nd stage amplifier. Do not exceed $V_{CC}+0.5V$ . Connect to $V_{CC}$ if not needed. Decoupling capacitor may be desired on application board for control line noise.
4	NC	No connection.
5	VCC	Power supply for the module. Recommending 1uF decoupling cap on the application board.
6	GND	Ground pin.
7	RFOUT	RF output pin. Internal DC block.
8	VCTRL	Gain control voltage; 0V to 3.3V range. Maximum gain at 0V. Recommending 0.1uF decoupling on the application board.
Center Pad	GND	Center ground pads need to have a good thermal path on the application board. Use solder stencil pattern shown in the document to define solder paste during assembly.

**Application Schematic**

(Without using final stage amplifier power down control)

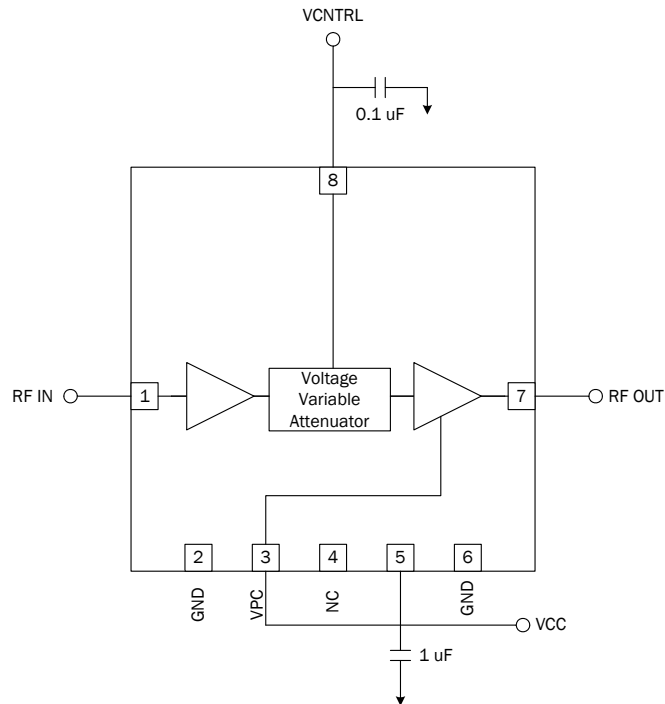

**Application Schematic**

(Using final stage amplifier power down control)

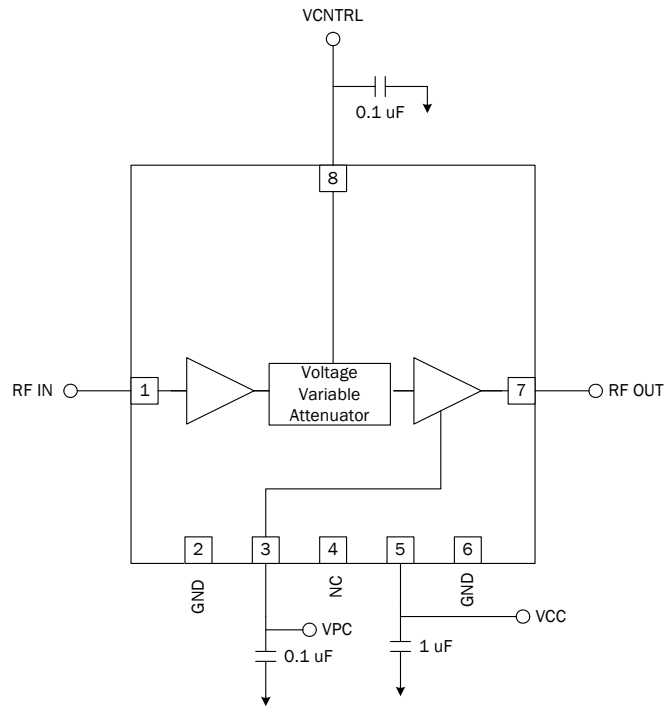

## Package Drawing

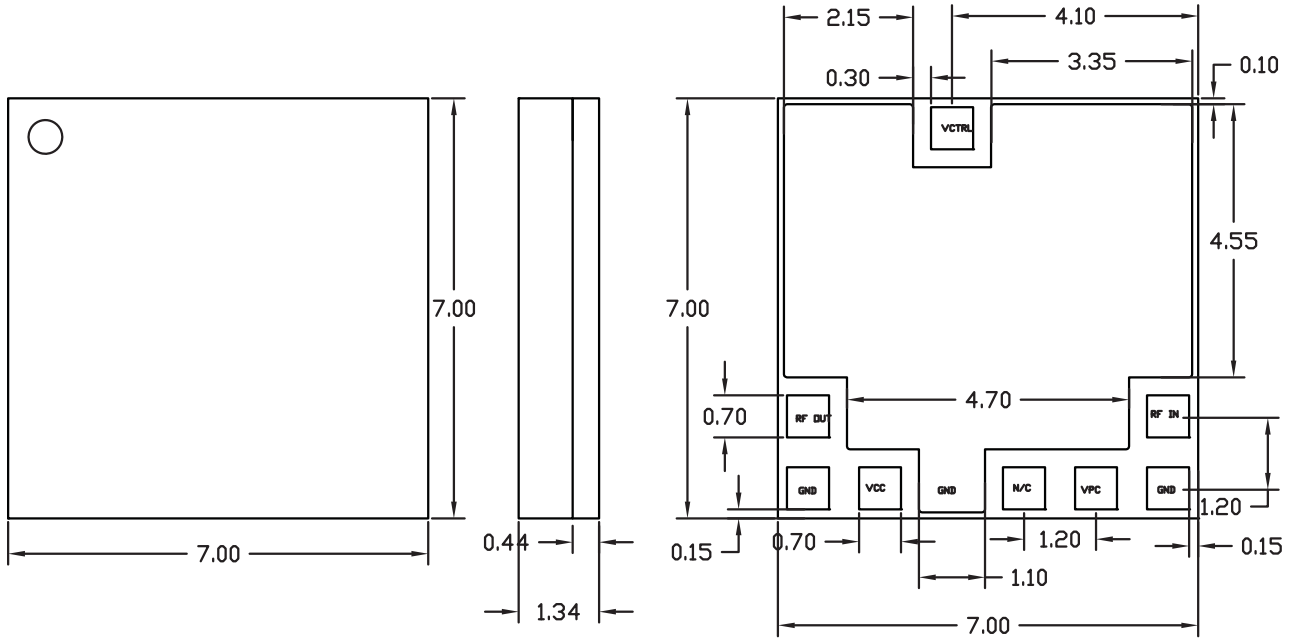

## Branding Diagram

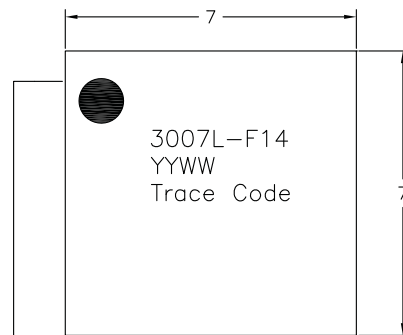

Pin 1 Indicator

Fill in the YYWW Notation with the Date Code

YY = Year

WW = Week

Trace Code to be assigned by SubCon



**Evaluation Board Assembly Drawing**

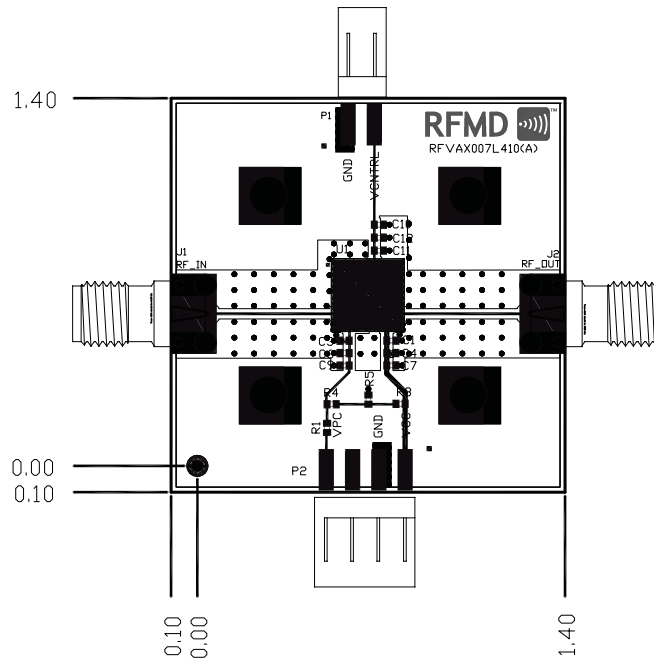

**PCB Design Requirements**

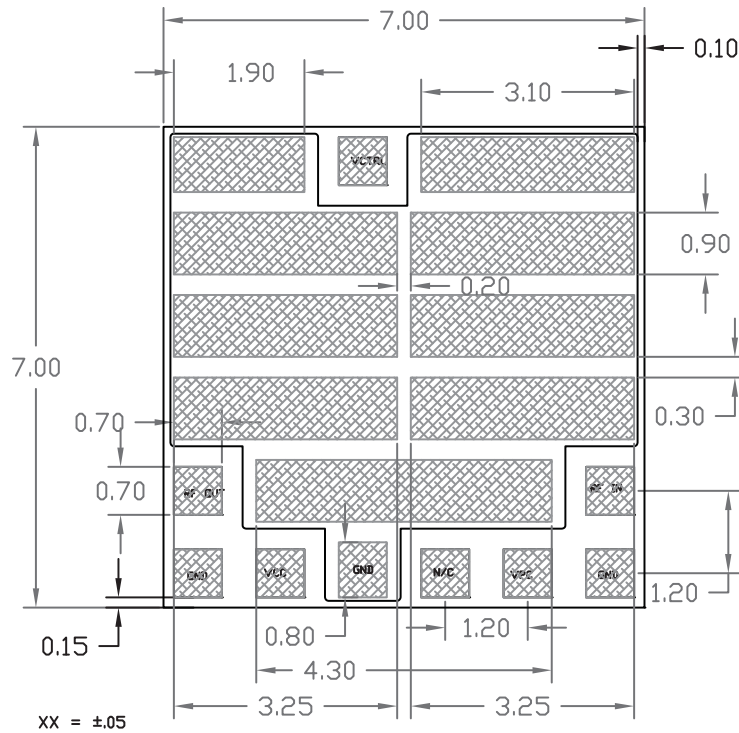

Note: This solder stencil pattern is required to prevent solder voiding that may impact thermal dissipation.