

RFSA2534

50MHz to 4000MHz, Digital Step Attenuator

RFMD's RFSA2534 is a 5-bit digital step attenuator (DSA) that features high linearity over the entire 15.5dB gain control range with 0.5dB steps. The RFSA2534 uses serial control interface. It has a low insertion loss of 1.3dB at 2GHz. Patent pending circuit architecture provides Overshoot-free transient switching performance. The RFSA2534 is available in a 4.2mm x 4.2mm laminate package that is footprint compatible with a 4mm x 4mm QFN 24 lead package.



Package: QFN, 24-pin,
4.2mm x 4.2mm x 0.95mm

Features

- 5-Bit, 15.5dB Range, 0.5dB Step
- Frequency Range 50MHz to 4000MHz
- Overshoot-free Transient Switching Performance
- High Linearity, Input IP3 = 55dBm
- Insertion Loss = 1.3dB at 2GHz
- Serial Control Interface
- Fast Switching Speed = 200ns
- Single Supply 3V to 5V Operation

Applications

- 2G through 4G Base Stations
- Point-to-Point
- WiMax/WiFi
- Test Equipment

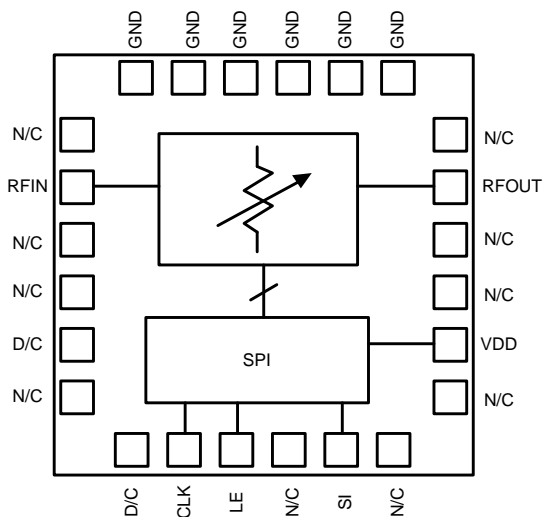

Functional Block Diagram

Ordering Information

RFSA2534SQ	Sample bag with 25 pieces
RFSA2534SR	7" Reel with 100 pieces
RFSA2534TR13	13" Reel with 2500 pieces
RFSA2534PCK-410	50MHz to 4000MHz PCBA with 5-piece sample bag

Absolute Maximum Ratings

Parameter	Rating	Unit
Supply Voltage (V_{DD})	-0.5 to +6.0	V
All Other DC and Logic Pins	-0.5 to +6.0	V
Maximum Input Power at RFIN Pins	+30	dBm
Maximum Input Power at RFOUT Pins	+27	dBm
Storage Temperature Range	-40 to +150	°C
ESD Rating - Human Body Model (HBM)	1000	V
Moisture Sensitivity Level	MSL3	



Caution! ESD sensitive device.



RFMD Green: RoHS status based on EU Directive 2011/65/EU (at time of this document revision), halogen free per IEC 61249-2-21, < 1000ppm each of antimony trioxide in polymeric materials and red phosphorus as a flame retardant, and <2% antimony in solder.

Exceeding any one or a combination of the Absolute Maximum Rating conditions may cause permanent damage to the device. Extended application of Absolute Maximum Rating conditions to the device may reduce device reliability. Specified typical performance or functional operation of the device under Absolute Maximum Rating conditions is not implied.

Recommended Operating Condition

Parameter	Specification			Unit
	Min	Typ	Max	
Operating Temperature Range (RF Input Power handling Derates Above 85°C)	-40		+105	°C
Operating Junction Temperature			125	°C
Supply Voltage ¹	2.7		5.5	V

Note 1: Device performance is constant over this range, LDO on chip

Nominal Operating Parameters

Parameter	Specification			Unit	Condition
	Min	Typ	Max		
General Performance					
Supply Current		230		μA	Steady state operation, current draw during attenuation state transitions is higher
Thermal Resistance		78		°C/W	
RF Input Power at RFIN Pin			27	dBm	Continuous operation at +85°C case temperature
RF Performance					
Frequency Range	50		4000	MHz	
Insertion Loss		1.3		dB	2000MHz, 0dB attenuation
Attenuation Range		15.5		dB	0.5dB step size
Absolute Attenuation Error	± (0.2 + 4%)			dB	
Input IP3		52		dBm	
Input P0.1dB		30		dBm	
Return Loss		15		dB	50MHz to 4000MHz, RFin and RFout pins, all attenuation states
Return Loss		18		dB	700MHz to 2300MHz, RFin and RFout pins, all attenuation states
Return Loss		22			2300MHz to 2700MHz, RFin and RFout pins, all attenuation states
Input and Output Impedance		50		Ω	

Parameter	Specification			Unit	Condition
	Min	Typ	Max		
Switching Speed		200		nsec	50% control to 10% / 90% RF
Successive Step Phase Delta		3		Deg	2000MHz
Control					
Digital Logic Low			0.8	V	
Digital Logic High	2.0		VDD	V	

Note: Typical performance at these conditions: Temp = +25°C, 2000MHz, 5V Supply Voltage

Typical Performance: T = 25°C, V_{DD} = 5V unless otherwise noted

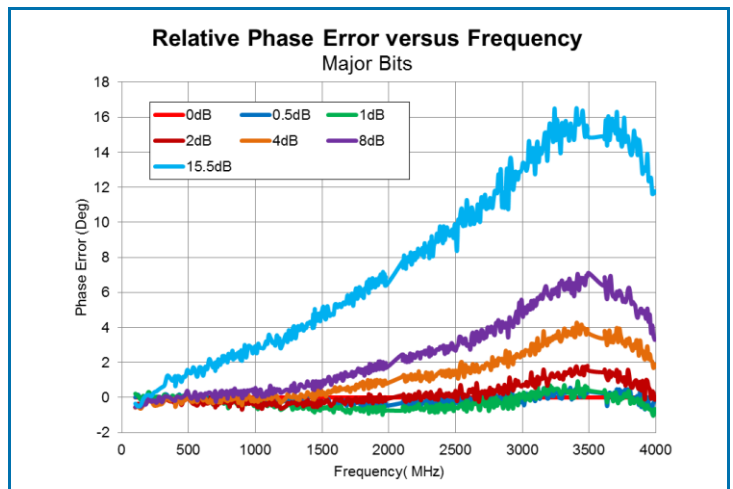
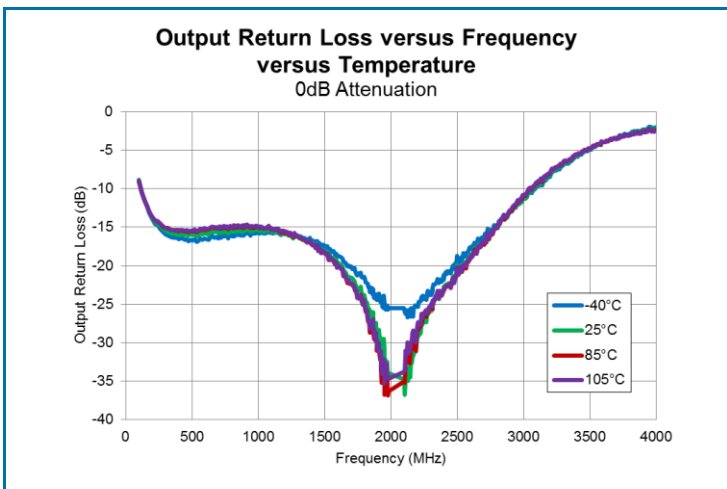
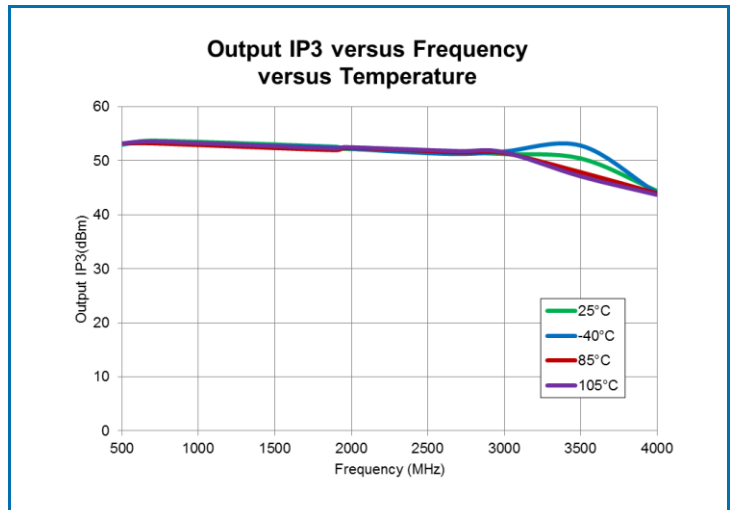
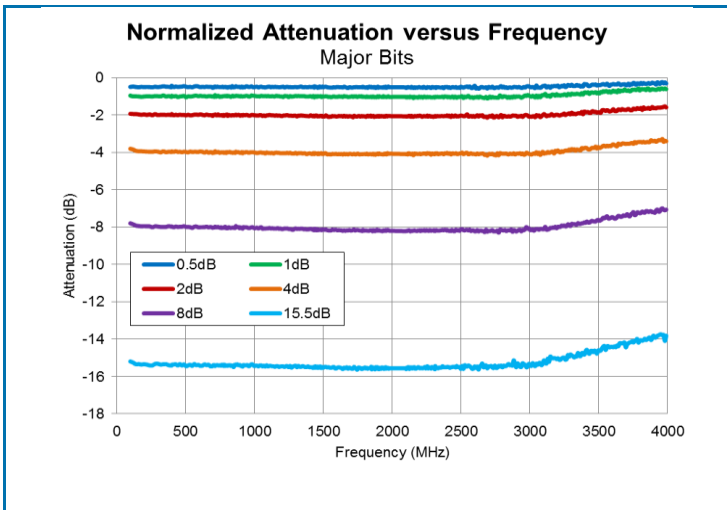
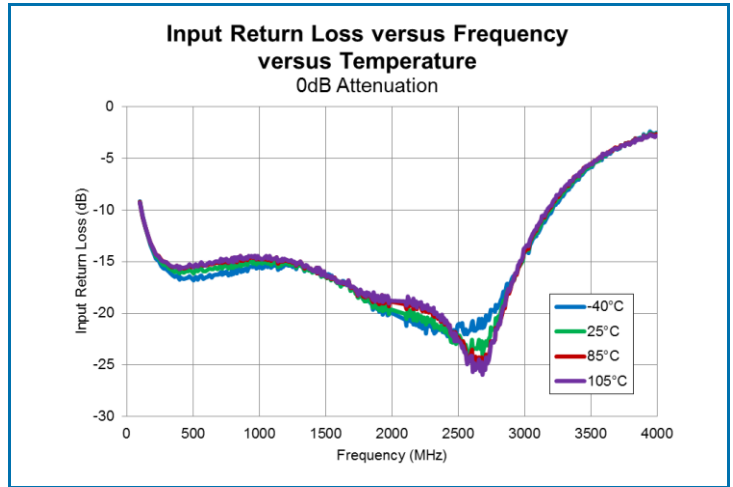
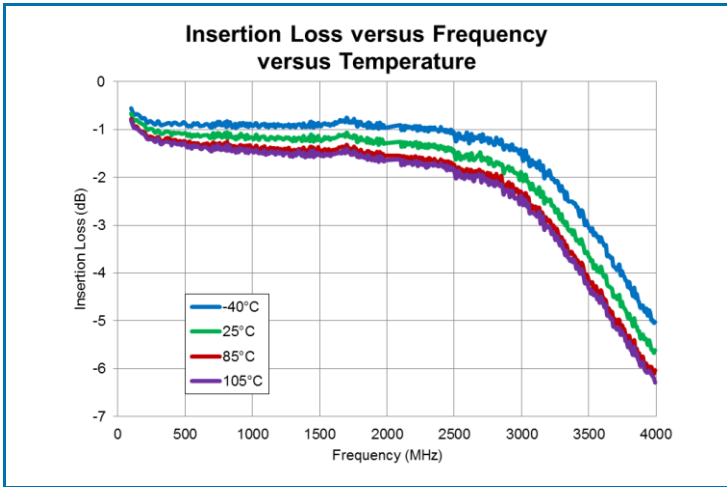

Typical Performance: T = 25°C, V_{DD} = 5V unless otherwise noted

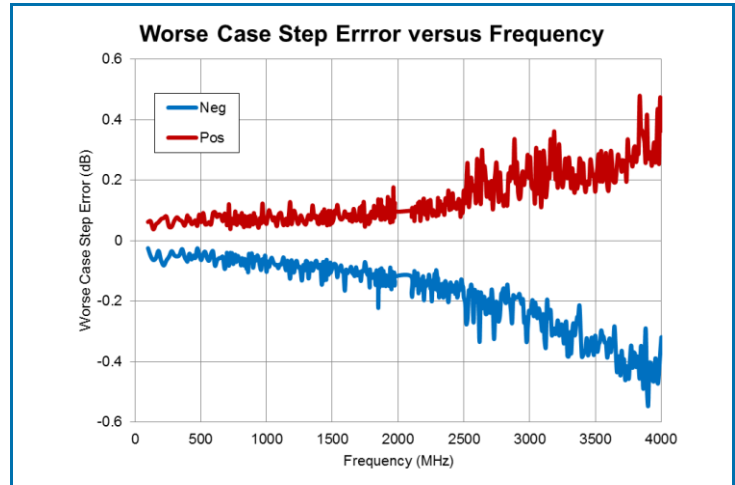
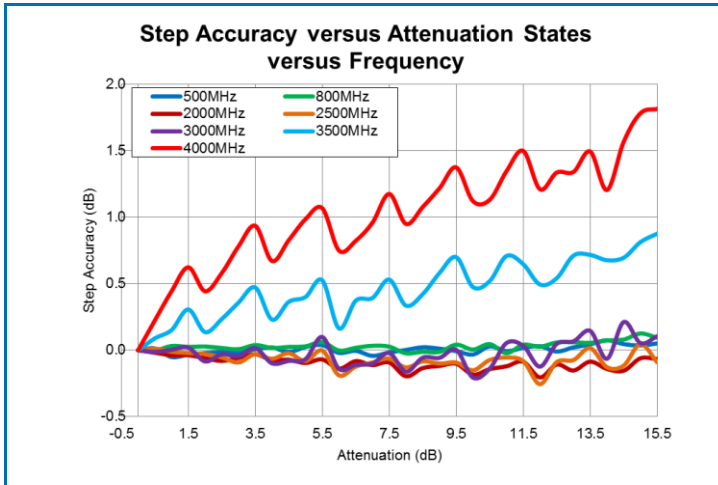

Evaluation Board Schematic 50MHz to 4000MHz Application Circuit

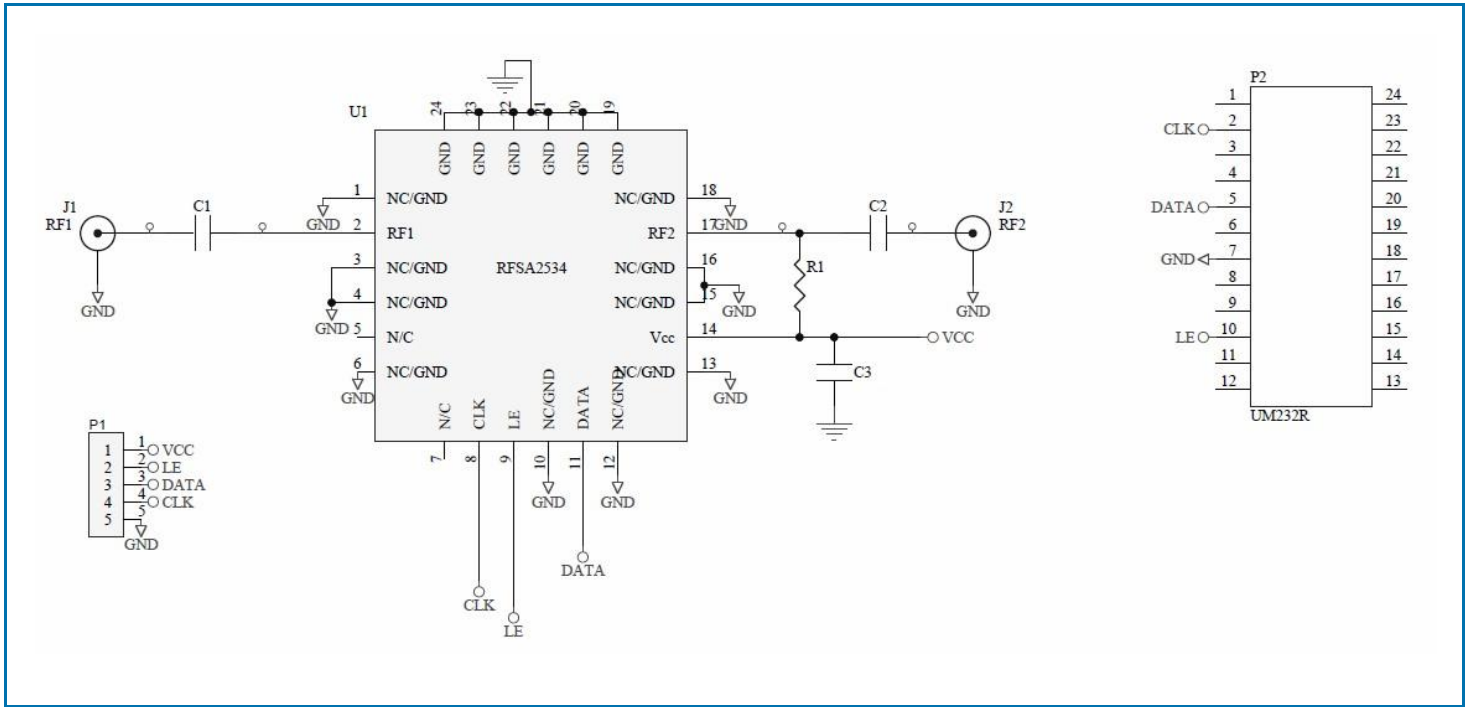

Evaluation Board Bill of Materials (BOM) 50MHz to 4000MHz Application Circuit

Description	Reference Designator	Manufacturer	Manufacturer's P/N
Evaluation Board		Performance Micro International Pt	RFSA2534-410(B)
RFSA2534 Module	U1	RFMD	RFSA2534
CAP, 100pF, 5%, 50V, C0G, 0402	C1-C2	Taiyo Yuden (USA), Inc.	RM UMK105 CG101JV-F
CAP, 10000pF, 10%, 16V, X7R, 0402	C3	Taiyo Yuden (USA), Inc.	RM EMK105 BJ103KV-F
CONN, SMA, END LNCH, UNIV, HYB MNT, FLT	J1-J2	Heilind Electronics	PER MAT-21-1038
CONN, HDR, ST, PLRZD, 5-PIN, 0.100"	P1	AMP	640454-5
CONN, SKT, 24-PIN DIP, 0.600", T/H	P2	Aries Electronics Inc.	24-6518-10

Evaluation Board Assembly Drawing 50MHz to 4000MHz Application Circuit

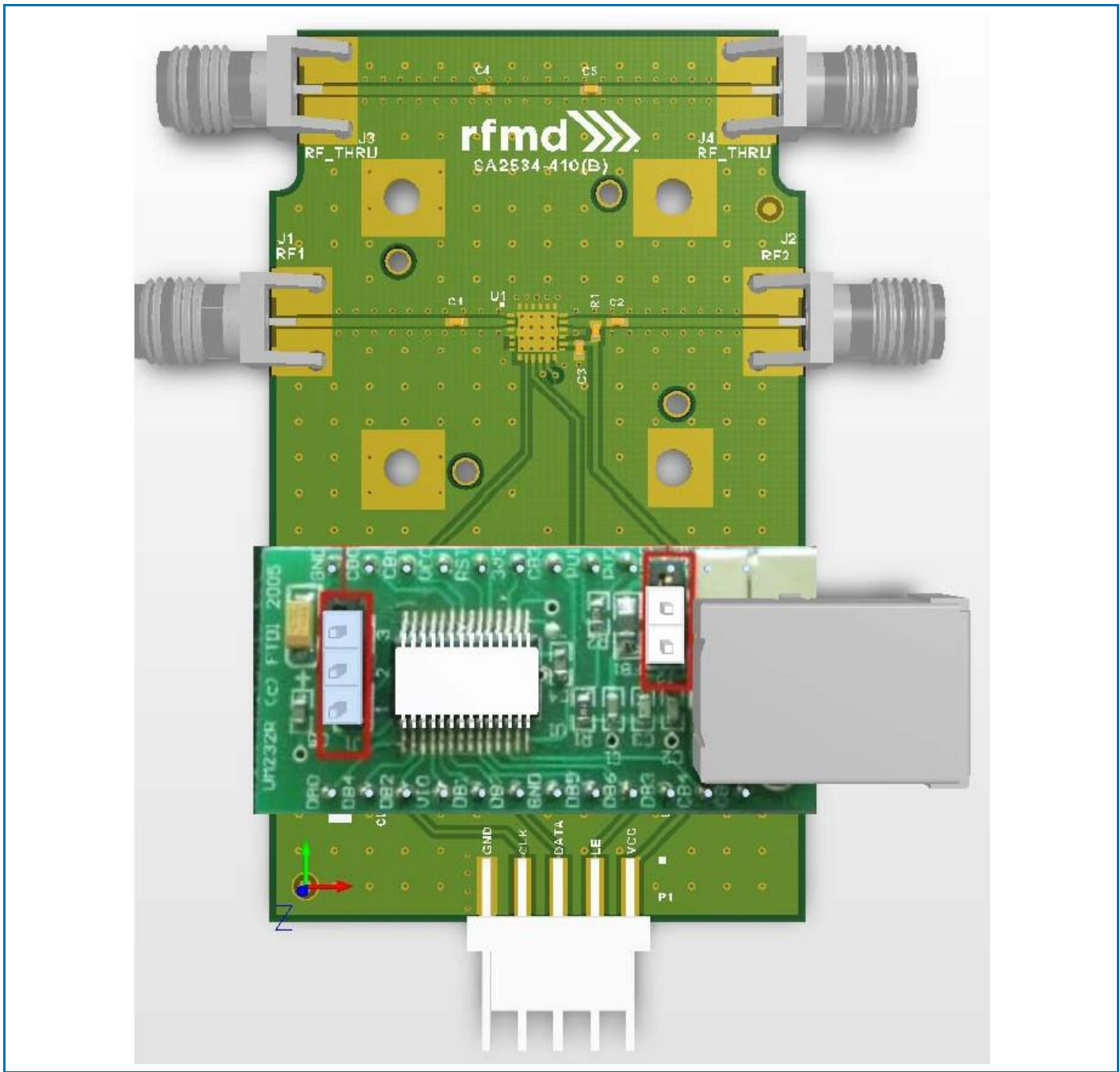

Serial Attenuation Word Truth Table

Attenuation Word					Attenuation State
D0.5	D1	D2	D4	D8	
H	H	H	H	H	0dB / Reference Insertion Loss
L	H	H	H	H	0.5dB
H	L	H	H	H	1dB
H	H	L	H	H	2dB
H	H	H	L	H	4dB
H	H	H	H	L	8dB
L	L	L	L	L	15.5dB max attenuation

Timing Diagram

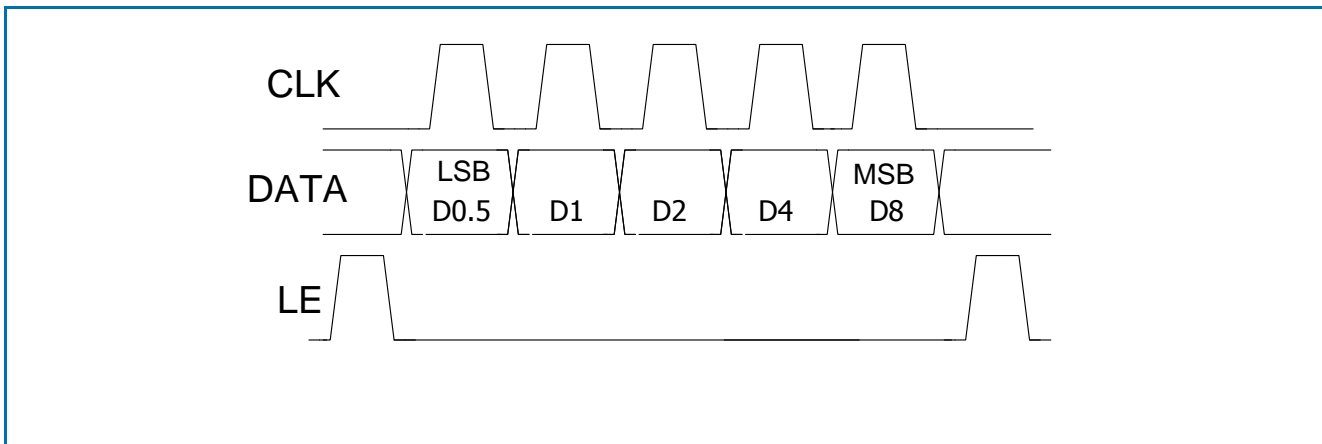

Timing Specifications

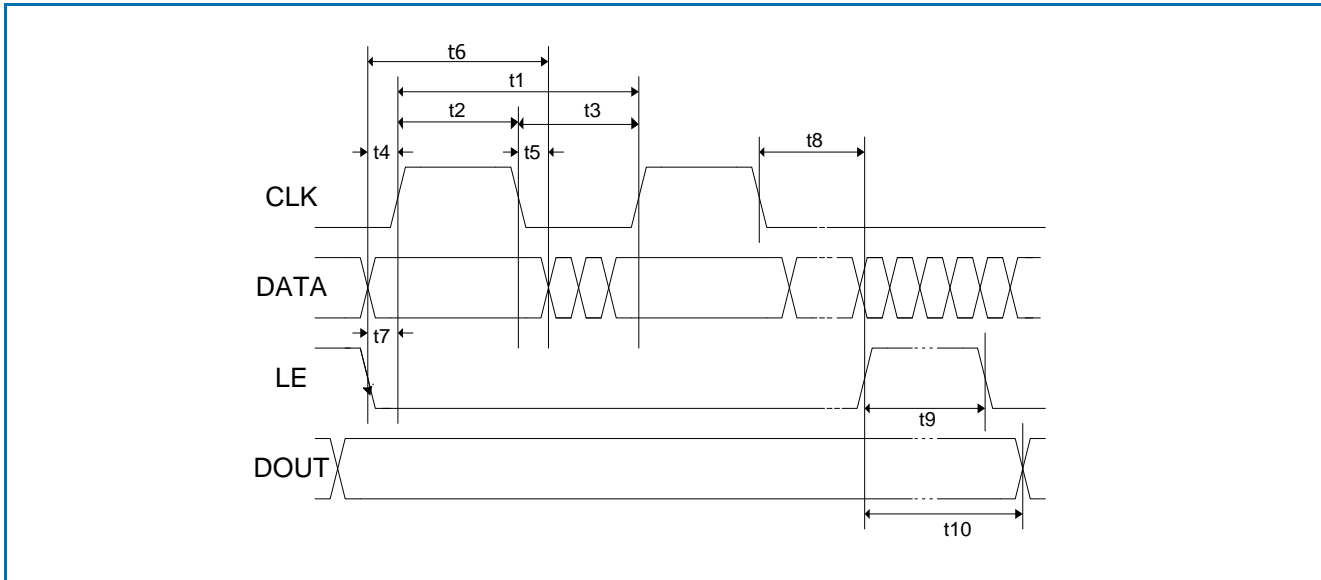

Timing Diagram Specifications

Parameter	Limit	Unit	Comment
t_1	25	MHz, max	CLK Frequency
t_2	20	ns min	CLK High
t_3	20	ns min	CLK Low
t_4	5	ns min	DATA to CLK Setup Time
t_5	5	ns min	DATA to CLK Hold Time
t_6	30	ns min	DATA Valid
t_7	5	ns min	LE to CLK Setup Time
t_8	5	ns min	CLK to LE Setup Time
t_9	10	ns min	LE Pulse Width
t_{10}	20	ns max	Output Set

Pin Names and Descriptions

Pin	Name	Description
1	NC	No Connect
2	RFIN	RF Input: Incident RF power must enter this pin for rated thermal performance and reliability. Do not apply DC power to this pin. Pin may be DC grounded externally and is grounded thru resistors internal to the part.
3	NC	No Connect
4	DC	Don't Care: This pin is open inside the package
5	NC	No Connect
6	NC	No Connect
7	DC	Don't Care: This pin is open inside the package
8	CLK	Serial Clock Input
9	LE	Latch Enable: The leading edge of signal on LE causes the attenuator to change state
10	NC	No Connect
11	SI	Serial Data Input
12	NC	No Connect
13	NC	No Connect
14	VDD	Supply for DSA and logic circuitry
15	NC	No Connect
16	NC	No Connect
17	RFOUT	RF Output: Incident RF power must enter this pin for rated thermal performance and reliability. Do not apply DC power to this pin. Pin may be DC grounded externally and is grounded thru resistors internal to the part.
18	NC	No Connect
19	GND	Ground this pin on the PCB
20	GND	Ground this pin on the PCB
21	GND	Ground this pin on the PCB
22	GND	Ground this pin on the PCB
23	GND	Ground this pin on the PCB
24	GND	Ground this pin on the PCB

Package Outline and Branding Drawing (Dimensions in millimeters)

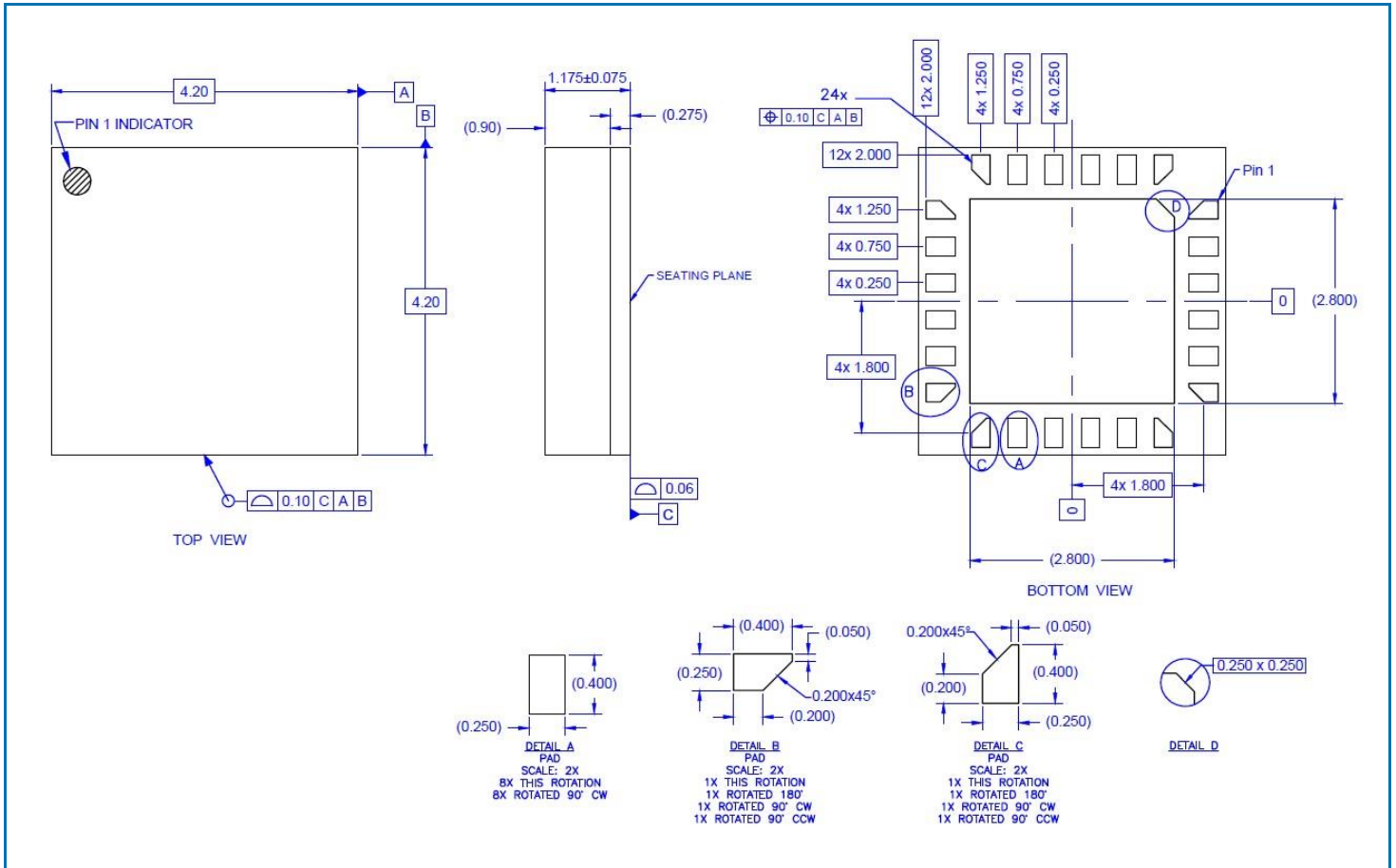

Branding Diagram

