

# NGD18N45CLB

## Ignition IGBT 18 Amps, 450 Volts

### N-Channel DPAK

This Logic Level Insulated Gate Bipolar Transistor (IGBT) features monolithic circuitry integrating ESD and Over-Voltage clamped protection for use in inductive coil drivers applications. Primary uses include Ignition, Direct Fuel Injection, or wherever high voltage and high current switching is required.

#### Features

- Ideal for Coil-on-Plug Applications
- DPAK Package Offers Smaller Footprint for Increased Board Space
- Gate-Emitter ESD Protection
- Temperature Compensated Gate-Collector Voltage Clamp Limits Stress Applied to Load
- Low Threshold Voltage Interfaces Power Loads to Logic or Microprocessor Devices
- Low Saturation Voltage
- High Pulsed Current Capability
- Emitter Ballasting for Short-Circuit Capability
- This is a Pb-Free Device

#### MAXIMUM RATINGS ( $T_J = 25^\circ\text{C}$ unless otherwise noted)

| Rating                                                                                | Symbol         | Value          | Unit                               |
|---------------------------------------------------------------------------------------|----------------|----------------|------------------------------------|
| Collector-Emitter Voltage                                                             | $V_{CES}$      | 500            | $V_{DC}$                           |
| Collector-Gate Voltage                                                                | $V_{CER}$      | 500            | $V_{DC}$                           |
| Gate-Emitter Voltage                                                                  | $V_{GE}$       | 18             | $V_{DC}$                           |
| Collector Current-Continuous<br>@ $T_C = 25^\circ\text{C}$ - Pulsed                   | $I_C$          | 18<br>50       | $A_{DC}$<br>$A_{AC}$               |
| ESD (Human Body Model)<br>$R = 1500 \Omega$ , $C = 100 \text{ pF}$                    | ESD            | 8.0            | kV                                 |
| ESD (Machine Model) $R = 0 \Omega$ , $C = 200 \text{ pF}$                             | ESD            | 400            | V                                  |
| Total Power Dissipation @ $T_C = 25^\circ\text{C}$<br>Derate above $25^\circ\text{C}$ | $P_D$          | 115<br>0.77    | Watts<br>$\text{W}/^\circ\text{C}$ |
| Operating and Storage Temperature Range                                               | $T_J, T_{stg}$ | -55 to<br>+175 | $^\circ\text{C}$                   |

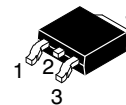
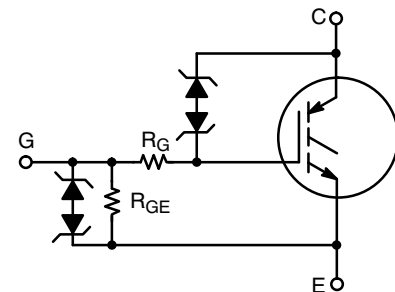
Stresses exceeding Maximum Ratings may damage the device. Maximum Ratings are stress ratings only. Functional operation above the Recommended Operating Conditions is not implied. Extended exposure to stresses above the Recommended Operating Conditions may affect device reliability.



**ON Semiconductor®**

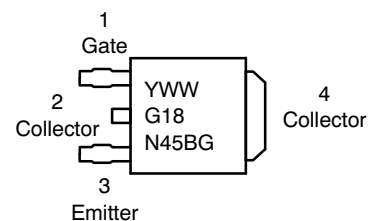
<http://onsemi.com>

**18 AMPS**  
**450 VOLTS**  
 $V_{CE(on)} \leq 2.1 \text{ V @}$   
 $I_C = 10 \text{ A}, V_{GE} \geq 4.5 \text{ V}$



**DPAK  
CASE 369C  
STYLE 7**

#### MARKING DIAGRAM



G18N45B = Device Code  
Y = Year  
WW = Work Week  
G = Pb-Free Device

#### ORDERING INFORMATION

| Device        | Package           | Shipping†        |
|---------------|-------------------|------------------|
| NGD18N45CLB4G | DPAK<br>(Pb-Free) | 2500/Tape & Reel |

†For information on tape and reel specifications, including part orientation and tape sizes, please refer to our Tape and Reel Packaging Specification Brochure, BRD8011/D.

# NGD18N45CLB

## UNCLAMPED COLLECTOR-TO-EMITTER AVALANCHE CHARACTERISTICS (Note 2)

| Characteristic                                                                                                                                                                                                                                                                                                                                                                                                                                                                                                                                                                                                           | Symbol   | Value                    | Unit |
|--------------------------------------------------------------------------------------------------------------------------------------------------------------------------------------------------------------------------------------------------------------------------------------------------------------------------------------------------------------------------------------------------------------------------------------------------------------------------------------------------------------------------------------------------------------------------------------------------------------------------|----------|--------------------------|------|
| Single Pulse Collector-to-Emitter Avalanche Energy<br>$V_{CC} = 50\text{ V}$ , $V_{GE} = 5.0\text{ V}$ , Pk $I_L = 26.0\text{ A}$ , $L = 1.0\text{ mH}$ , Starting $T_J = 25^\circ\text{C}$<br>$V_{CC} = 50\text{ V}$ , $V_{GE} = 5.0\text{ V}$ , Pk $I_L = 10.0\text{ A}$ , $L = 8.4\text{ mH}$ , Starting $T_J = 25^\circ\text{C}$<br>$V_{CC} = 50\text{ V}$ , $V_{GE} = 5.0\text{ V}$ , Pk $I_L = 15.4\text{ A}$ , $L = 2.0\text{ mH}$ , Starting $T_J = 150^\circ\text{C}$<br>$V_{CC} = 50\text{ V}$ , $V_{GE} = 5.0\text{ V}$ , Pk $I_L = 5.7\text{ A}$ , $L = 15.2\text{ mH}$ , Starting $T_J = 150^\circ\text{C}$ | $E_{AS}$ | 338<br>420<br>237<br>247 | mJ   |

## MAXIMUM SHORT-CIRCUIT TIMES

|                                                                                                                  |             |      |               |
|------------------------------------------------------------------------------------------------------------------|-------------|------|---------------|
| Short Circuit Withstand Time – Test 1<br>(See Figure 17, 3 Pulses with 10 ms Period, $T_a = 105^\circ\text{C}$ ) | $t_{sc1-1}$ | 1000 | $\mu\text{S}$ |
| Short Circuit Withstand Time – Test 1<br>(See Figure 17, 3 Pulses with 10 ms Period, $T_a = 150^\circ\text{C}$ ) | $t_{sc1-2}$ | 800  | $\mu\text{S}$ |
| Short Circuit Withstand Time – Test 2<br>(See Figure 18, 3 Pulses with 10 ms Period, $T_a = 105^\circ\text{C}$ ) | $t_{sc2-1}$ | 5    | ms            |
| Short Circuit Withstand Time – Test 2<br>(See Figure 18, 3 Pulses with 10 ms Period, $T_a = 150^\circ\text{C}$ ) | $t_{sc2-2}$ | 1    | ms            |

## THERMAL CHARACTERISTICS

|                                                                               |                                  |     |                    |
|-------------------------------------------------------------------------------|----------------------------------|-----|--------------------|
| Thermal Resistance, Junction to Case                                          | $R_{\theta JC}$                  | 1.3 | $^\circ\text{C/W}$ |
| Thermal Resistance, Junction to Ambient                                       | $R_{\theta JA}$<br>DPAK (Note 1) | 95  | $^\circ\text{C/W}$ |
| Maximum Lead Temperature for Soldering Purposes, 1/8" from case for 5 seconds | $T_L$                            | 275 | $^\circ\text{C}$   |

## ELECTRICAL CHARACTERISTICS

| Characteristic | Symbol | Test Conditions | Temperature | Min | Typ | Max | Unit |
|----------------|--------|-----------------|-------------|-----|-----|-----|------|
|----------------|--------|-----------------|-------------|-----|-----|-----|------|

### OFF CHARACTERISTICS (Note 2)

|                                           |               |                                                    |                                                  |     |     |     |                    |
|-------------------------------------------|---------------|----------------------------------------------------|--------------------------------------------------|-----|-----|-----|--------------------|
| Collector-Emitter Clamp Voltage           | $BV_{CES}$    | $I_C = 2.0\text{ mA}$                              | $T_J = -40^\circ\text{C}$ to $150^\circ\text{C}$ | 430 | 455 | 470 | $V_{DC}$           |
|                                           |               | $I_C = 10\text{ mA}$                               | $T_J = -40^\circ\text{C}$ to $150^\circ\text{C}$ | 440 | 475 | 500 |                    |
| Zero Gate Voltage Collector Current       | $I_{CES}$     | $V_{CE} = 350\text{ V}$ ,<br>$V_{GE} = 0\text{ V}$ | $T_J = 25^\circ\text{C}$                         | -   | 0.5 | 20  | $\mu\text{A}_{DC}$ |
|                                           |               |                                                    | $T_J = 150^\circ\text{C}$                        | -   | 75  | 250 |                    |
|                                           |               |                                                    | $T_J = -40^\circ\text{C}$                        | -   | 0.2 | 10  |                    |
|                                           |               | $V_{CE} = 15\text{ V}$ ,<br>$V_{GE} = 0\text{ V}$  | $T_J = 25^\circ\text{C}$                         | -   | -   | 2.0 |                    |
| Reverse Collector-Emitter Leakage Current | $I_{ECS}$     | $V_{CE} = -24\text{ V}$                            | $T_J = 25^\circ\text{C}$                         | -   | 0.7 | 1.0 | mA                 |
|                                           |               |                                                    | $T_J = 150^\circ\text{C}$                        | -   | 12  | 25  |                    |
|                                           |               |                                                    | $T_J = -40^\circ\text{C}$                        | -   | 0.1 | 1.0 |                    |
| Reverse Collector-Emitter Clamp Voltage   | $BV_{CES(R)}$ | $I_C = -75\text{ mA}$                              | $T_J = 25^\circ\text{C}$                         | 24  | 27  | 30  | $V_{DC}$           |
|                                           |               |                                                    | $T_J = 150^\circ\text{C}$                        | 26  | 29  | 33  |                    |
|                                           |               |                                                    | $T_J = -40^\circ\text{C}$                        | 23  | 26  | 29  |                    |
| Gate-Emitter Clamp Voltage                | $BV_{GES}$    | $I_G = 5.0\text{ mA}$                              | $T_J = -40^\circ\text{C}$ to $150^\circ\text{C}$ | 11  | 13  | 15  | $V_{DC}$           |
| Gate-Emitter Leakage Current              | $I_{GES}$     | $V_{GE} = 10\text{ V}$                             | $T_J = -40^\circ\text{C}$ to $150^\circ\text{C}$ | 384 | 590 | 700 | $\mu\text{A}_{DC}$ |
| Gate Resistor                             | $R_G$         | -                                                  | $T_J = -40^\circ\text{C}$ to $150^\circ\text{C}$ | -   | 70  | -   | $\Omega$           |
| Gate Emitter Resistor                     | $R_{GE}$      | -                                                  | $T_J = -40^\circ\text{C}$ to $150^\circ\text{C}$ | 10  | 16  | 26  | k $\Omega$         |

1. When surface mounted to an FR4 board using the minimum recommended pad size.

# NGD18N45CLB

## ELECTRICAL CHARACTERISTICS (continued)

| Characteristic | Symbol | Test Conditions | Temperature | Min | Typ | Max | Unit |
|----------------|--------|-----------------|-------------|-----|-----|-----|------|
|----------------|--------|-----------------|-------------|-----|-----|-----|------|

### ON CHARACTERISTICS (Note 2)

|                                              |              |                                                   |                                                  |      |      |      |                            |
|----------------------------------------------|--------------|---------------------------------------------------|--------------------------------------------------|------|------|------|----------------------------|
| Gate Threshold Voltage                       | $V_{GE(th)}$ | $I_C = 1.0 \text{ mA}$ ,<br>$V_{GE} = V_{CE}$     | $T_J = 25^\circ\text{C}$                         | 1.1  | 1.56 | 1.9  | $V_{DC}$                   |
|                                              |              |                                                   | $T_J = 150^\circ\text{C}$                        | 0.75 | 1.08 | 1.4  |                            |
|                                              |              |                                                   | $T_J = -40^\circ\text{C}$                        | 1.2  | 1.75 | 2.1  |                            |
| Collector-to-Emitter On-Voltage              | $V_{CE(on)}$ | $I_C = 7 \text{ A}$ ,<br>$V_{GE} = 4.5 \text{ V}$ | $T_J = -40^\circ\text{C}$ to $150^\circ\text{C}$ | 1.10 | 1.84 | 2.30 | V                          |
|                                              |              |                                                   | $T_J = -40^\circ\text{C}$ to $150^\circ\text{C}$ | 1.15 | 1.89 | 2.35 |                            |
|                                              |              |                                                   | $T_J = -40^\circ\text{C}$ to $150^\circ\text{C}$ | 1.20 | 1.93 | 2.50 |                            |
|                                              |              |                                                   | $T_J = -40^\circ\text{C}$ to $150^\circ\text{C}$ | 1.45 | 2.07 | 2.65 |                            |
|                                              |              |                                                   | $T_J = -40^\circ\text{C}$ to $150^\circ\text{C}$ | 1.50 | 2.13 | 2.80 |                            |
|                                              |              |                                                   | $T_J = -40^\circ\text{C}$ to $150^\circ\text{C}$ | 1.55 | 2.19 | 2.85 |                            |
|                                              |              |                                                   | $T_J = -40^\circ\text{C}$ to $150^\circ\text{C}$ | -    | 0.65 | 1.00 |                            |
| Threshold Temperature Coefficient (Negative) | -            | -                                                 | -                                                | -    | 3.5  | -    | $\text{mV}/^\circ\text{C}$ |
| Forward Transconductance                     | gfs          | $V_{CE} = 5.0 \text{ V}$ , $I_C = 6.0 \text{ A}$  | $T_J = -40^\circ\text{C}$ to $150^\circ\text{C}$ | 6.0  | 14   | 25   | Mhos                       |

### DYNAMIC CHARACTERISTICS (Note 2)

|                      |           |                                                                           |                                                  |     |     |      |    |
|----------------------|-----------|---------------------------------------------------------------------------|--------------------------------------------------|-----|-----|------|----|
| Input Capacitance    | $C_{ISS}$ | $V_{CC} = 25 \text{ V}$ , $V_{GE} = 0 \text{ V}$<br>$f = 1.0 \text{ MHz}$ | $T_J = -40^\circ\text{C}$ to $150^\circ\text{C}$ | 400 | 780 | 1000 | pF |
| Output Capacitance   | $C_{OSS}$ |                                                                           |                                                  | 50  | 72  | 100  |    |
| Transfer Capacitance | $C_{RSS}$ |                                                                           |                                                  | 4.0 | 6   | 10   |    |

### SWITCHING CHARACTERISTICS (Note 2)

|                     |              |                                                                                                      |                          |     |      |     |                 |
|---------------------|--------------|------------------------------------------------------------------------------------------------------|--------------------------|-----|------|-----|-----------------|
| Turn-Off Delay Time | $t_{d(off)}$ | $V_{CC} = 300 \text{ V}$ , $V_{GE} = 5 \text{ V}$<br>$R_G = 1.0 \text{ k}\Omega$ , $R_L = 46 \Omega$ | $T_J = 25^\circ\text{C}$ | 1.0 | 2.9  | 12  | $\mu\text{Sec}$ |
| Fall Time           | $t_f$        | $V_{CC} = 300 \text{ V}$ , $V_{GE} = 5 \text{ V}$<br>$R_G = 1.0 \text{ k}\Omega$ , $R_L = 46 \Omega$ | $T_J = 25^\circ\text{C}$ | 1.0 | 2.5  | 7.0 |                 |
| Turn-On Delay Time  | $t_{d(on)}$  | $V_{CC} = 14 \text{ V}$ , $V_{GE} = 5 \text{ V}$<br>$R_G = 1.0 \text{ k}\Omega$ , $R_L = 1 \Omega$   | $T_J = 25^\circ\text{C}$ | 0.1 | 0.42 | 1.4 | $\mu\text{Sec}$ |
| Rise Time           | $t_r$        | $V_{CC} = 14 \text{ V}$ , $V_{GE} = 5 \text{ V}$<br>$R_G = 1.0 \text{ k}\Omega$ , $R_L = 1 \Omega$   | $T_J = 25^\circ\text{C}$ | 1.0 | 2.5  | 9.0 |                 |

2. Electrical Characteristics at temperature other than 25°C, Dynamic and Switching characteristics are not subject to production testing.

# NGD18N45CLB

## TYPICAL ELECTRICAL CHARACTERISTICS (unless otherwise noted)

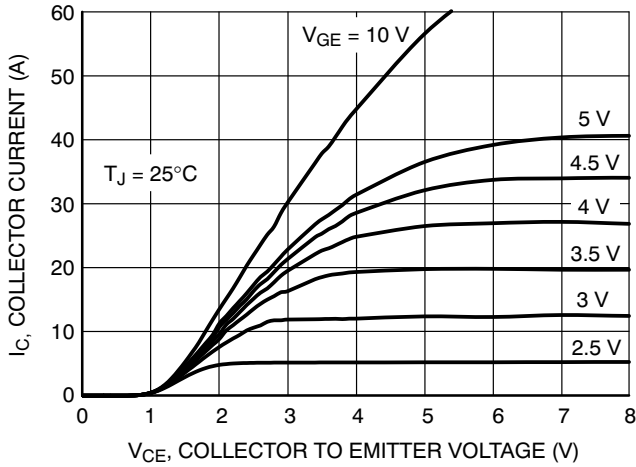


Figure 1. Output Characteristics

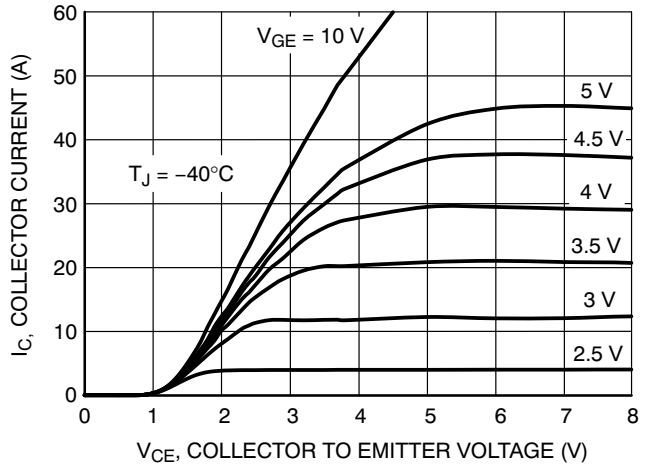


Figure 2. Output Characteristics

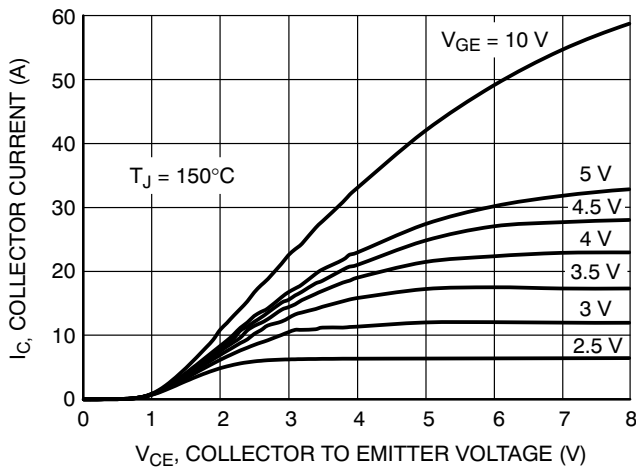


Figure 3. Output Characteristics

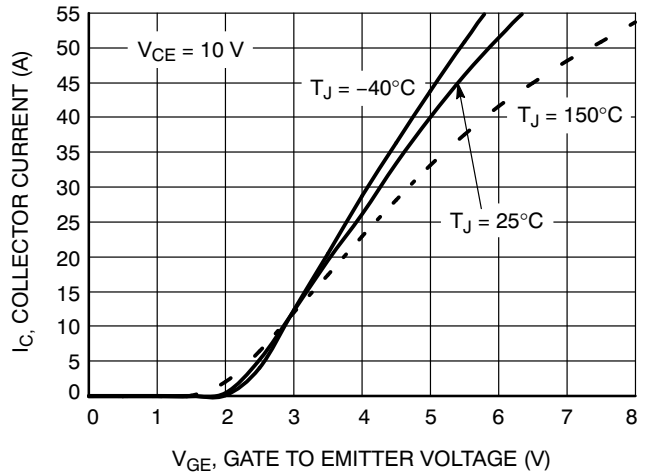


Figure 4. Transfer Characteristics

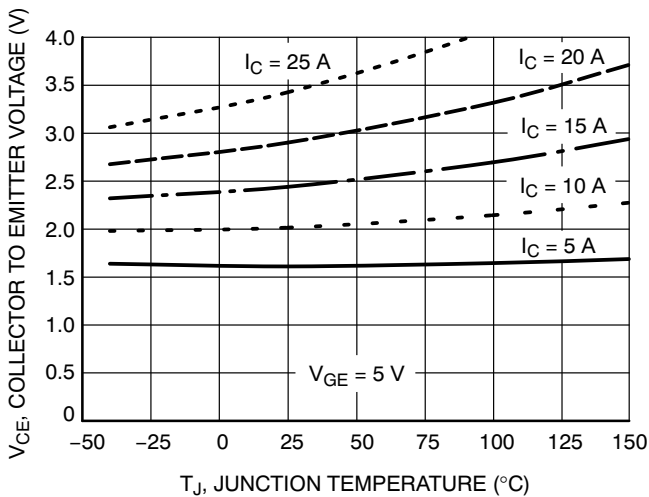


Figure 5. Collector-to-Emitter Saturation Voltage vs. Junction Temperature

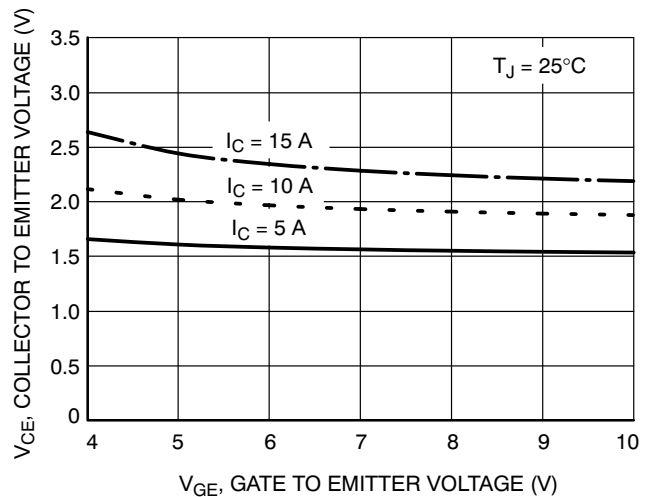
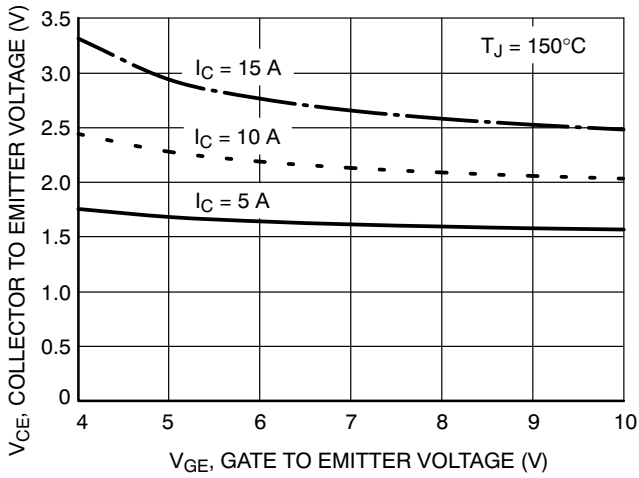
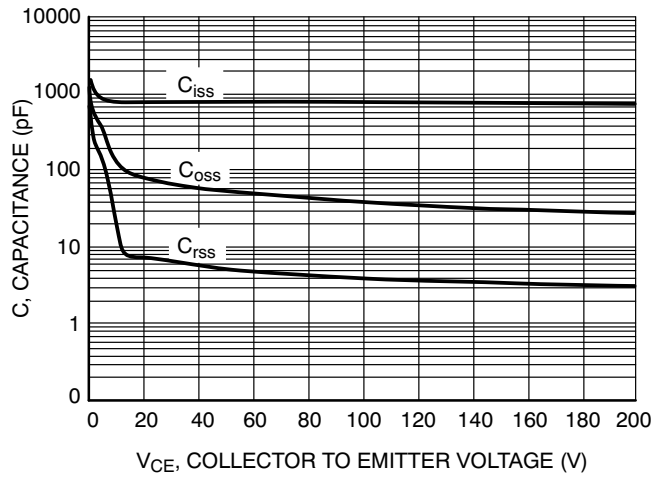


Figure 6. Collector-to-Emitter Voltage vs. Gate-to-Emitter Voltage

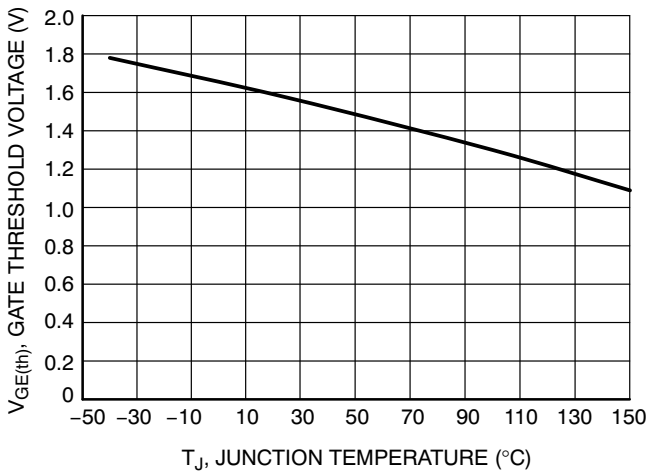
# NGD18N45CLB



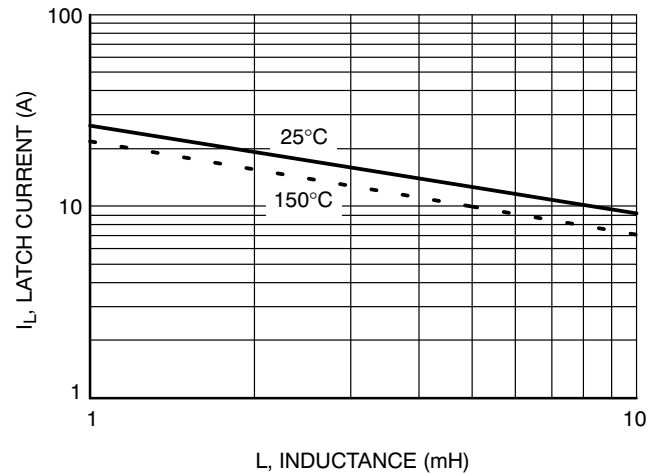
**Figure 7. Collector-to-Emitter Voltage vs. Gate-to-Emitter Voltage**



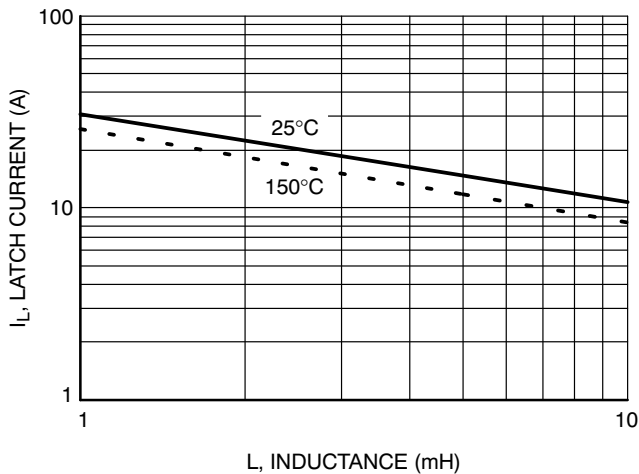
**Figure 8. Capacitance Variation**



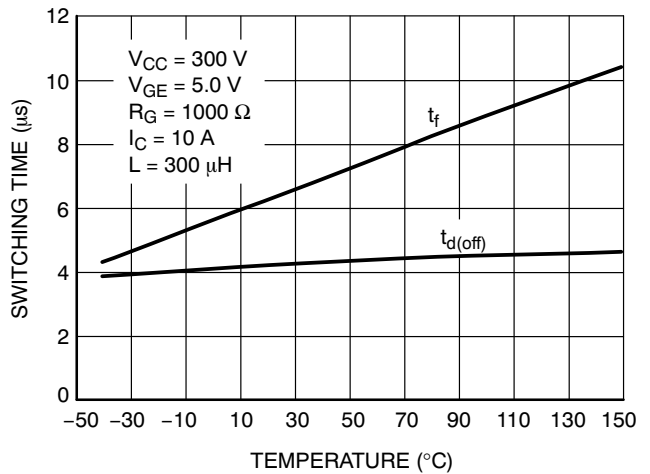
**Figure 9. Gate Threshold Voltage vs. Junction Temperature**



**Figure 10. Minimum Open Secondary Latch Current vs. Inductance**

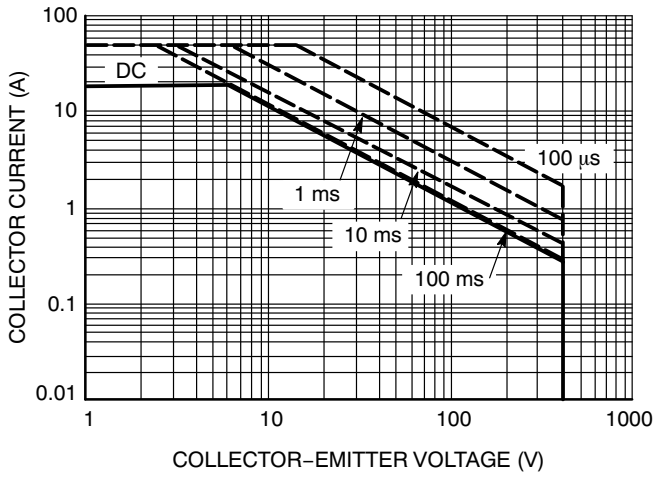


**Figure 11. Typical Open Secondary Latch Current vs. Inductance**

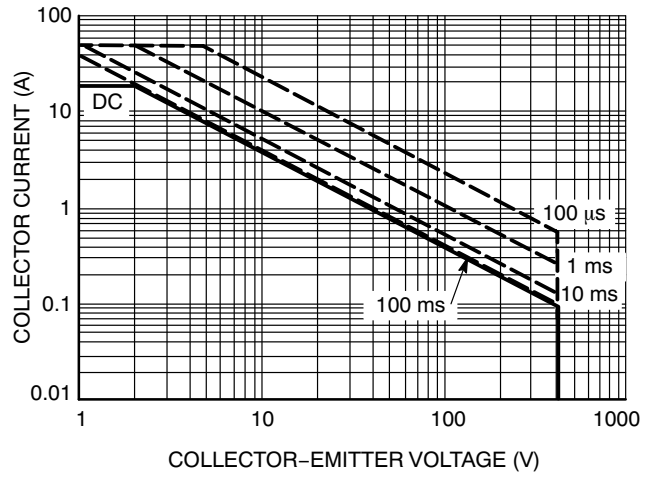


**Figure 12. Inductive Switching Fall Time vs. Temperature**

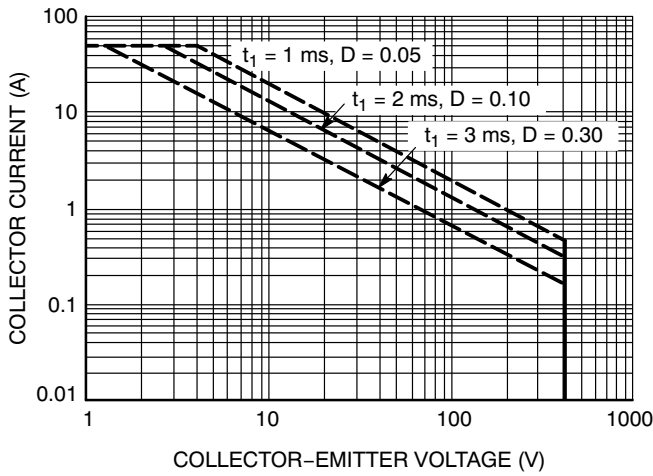
# NGD18N45CLB



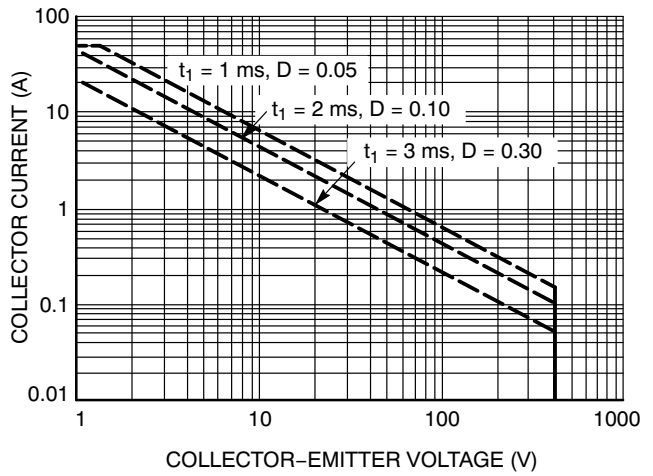
**Figure 13. Single Pulse Safe Operating Area (Mounted on an Infinite Heatsink at  $T_A = 25^\circ\text{C}$ )**



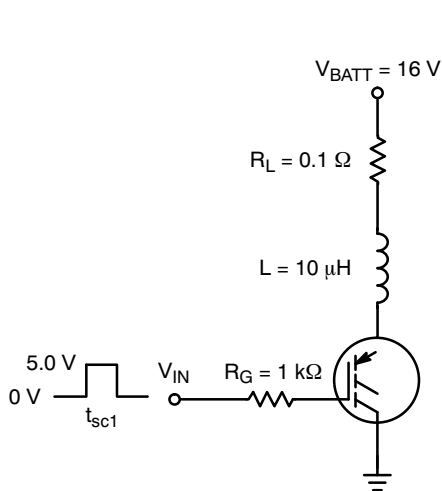
**Figure 14. Single Pulse Safe Operating Area (Mounted on an Infinite Heatsink at  $T_A = 125^\circ\text{C}$ )**



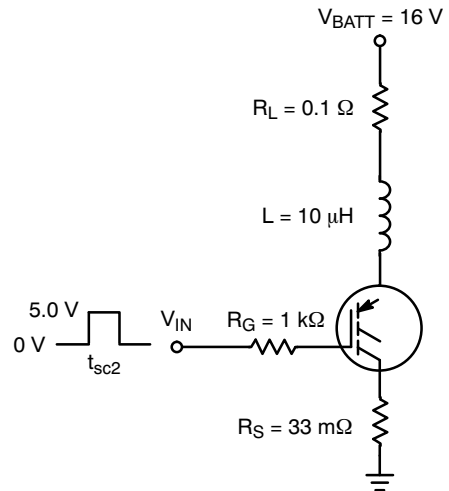
**Figure 15. Pulse Train Safe Operating Area (Mounted on an Infinite Heatsink at  $T_C = 25^\circ\text{C}$ )**



**Figure 16. Pulse Train Safe Operating Area (Mounted on an Infinite Heatsink at  $T_C = 125^\circ\text{C}$ )**

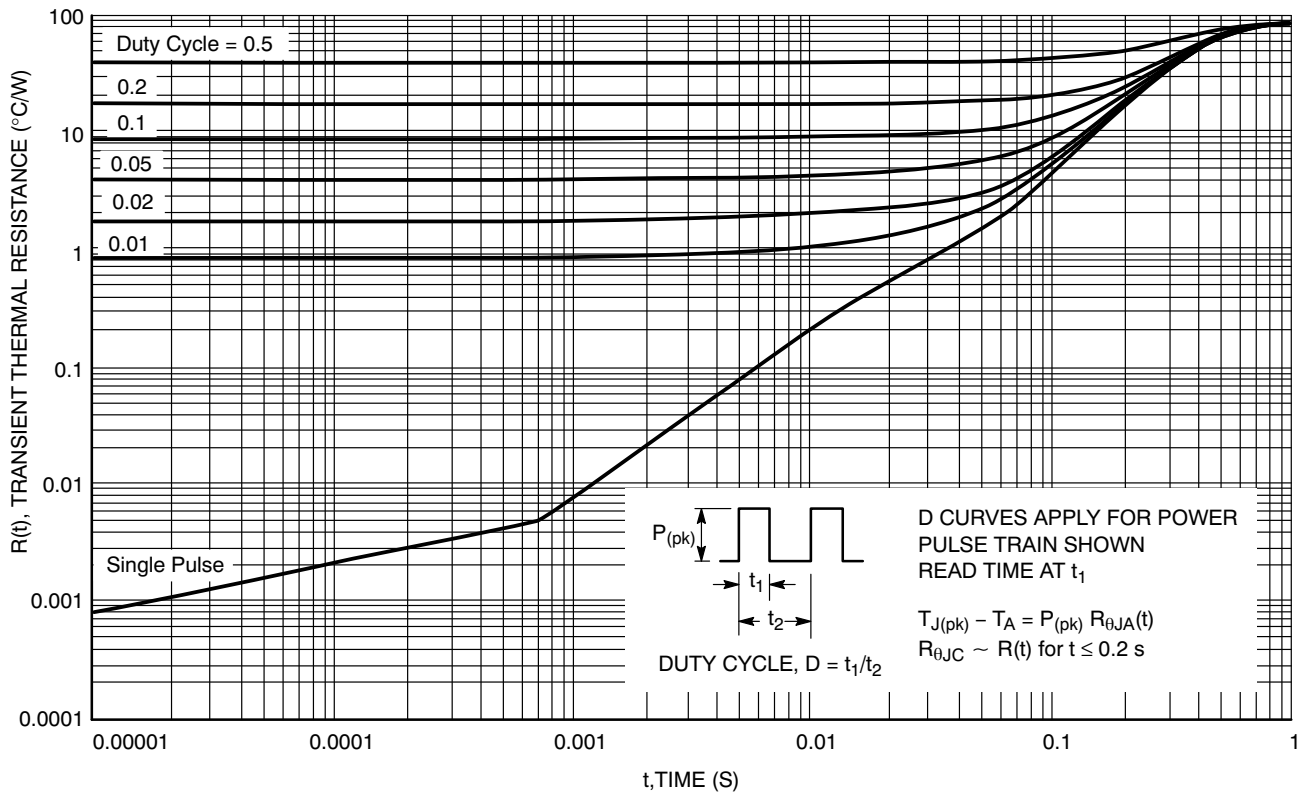


**Figure 17. Circuit Configuration for Short Circuit Test #1**



**Figure 18. Circuit Configuration for Short Circuit Test #2**

# NGD18N45CLB

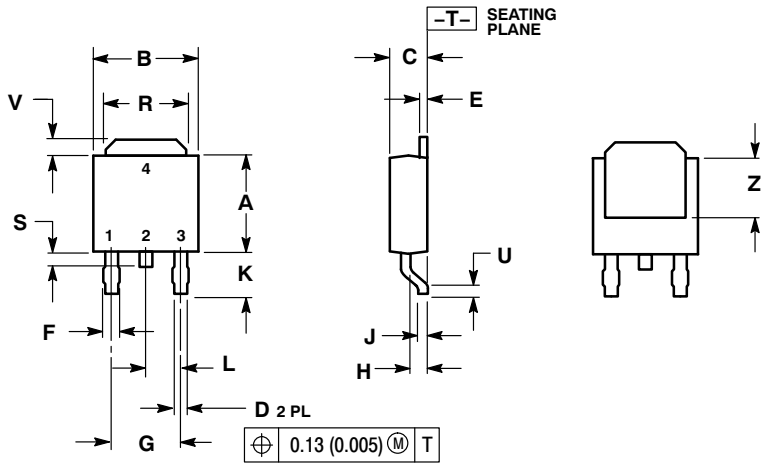


**Figure 19. Transient Thermal Resistance  
(Non-normalized Junction-to-Ambient mounted on minimum pad area)**

# NGD18N45CLB

## PACKAGE DIMENSIONS

### DPAK CASE 369C ISSUE C



- NOTES:  
 1. DIMENSIONING AND TOLERANCING PER ANSI Y14.5M, 1982.  
 2. CONTROLLING DIMENSION: INCH.

| DIM | INCHES    |       | MILLIMETERS |      |
|-----|-----------|-------|-------------|------|
|     | MIN       | MAX   | MIN         | MAX  |
| A   | 0.235     | 0.245 | 5.97        | 6.22 |
| B   | 0.250     | 0.265 | 6.35        | 6.73 |
| C   | 0.086     | 0.094 | 2.19        | 2.38 |
| D   | 0.027     | 0.035 | 0.69        | 0.88 |
| E   | 0.018     | 0.023 | 0.46        | 0.58 |
| F   | 0.037     | 0.045 | 0.94        | 1.14 |
| G   | 0.180 BSC |       | 4.58 BSC    |      |
| H   | 0.034     | 0.040 | 0.87        | 1.01 |
| J   | 0.018     | 0.023 | 0.46        | 0.58 |
| K   | 0.102     | 0.114 | 2.60        | 2.89 |
| L   | 0.090 BSC |       | 2.29 BSC    |      |
| R   | 0.180     | 0.215 | 4.57        | 5.45 |
| S   | 0.025     | 0.040 | 0.63        | 1.01 |
| U   | 0.020     | ---   | 0.51        | ---  |
| V   | 0.035     | 0.050 | 0.89        | 1.27 |
| Z   | 0.155     | ---   | 3.93        | ---  |

- STYLE 7:  
 PIN 1. GATE  
 2. COLLECTOR  
 3. EMITTER  
 4. COLLECTOR

ON Semiconductor and are registered trademarks of Semiconductor Components Industries, LLC (SCILLC). SCILLC owns the rights to a number of patents, trademarks, copyrights, trade secrets, and other intellectual property. A listing of SCILLC's product/patent coverage may be accessed at [www.onsemi.com/site/pdf/Patent-Markings.pdf](http://www.onsemi.com/site/pdf/Patent-Markings.pdf). SCILLC reserves the right to make changes without further notice to any products herein. SCILLC makes no warranty, representation or guarantee regarding the suitability of its products for any particular purpose, nor does SCILLC assume any liability arising out of the application or use of any product or circuit, and specifically disclaims any and all liability, including without limitation special, consequential or incidental damages. "Typical" parameters which may be provided in SCILLC data sheets and/or specifications can and do vary in different applications and actual performance may vary over time. All operating parameters, including "Typicals" must be validated for each customer application by customer's technical experts. SCILLC does not convey any license under its patent rights nor the rights of others. SCILLC products are not designed, intended, or authorized for use as components in systems intended for surgical implant into the body, or other applications intended to support or sustain life, or for any other application in which the failure of the SCILLC product could create a situation where personal injury or death may occur. Should Buyer purchase or use SCILLC products for any such unintended or unauthorized application, Buyer shall indemnify and hold SCILLC and its officers, employees, subsidiaries, affiliates, and distributors harmless against all claims, costs, damages, and expenses, and reasonable attorney fees arising out of, directly or indirectly, any claim of personal injury or death associated with such unintended or unauthorized use, even if such claim alleges that SCILLC was negligent regarding the design or manufacture of the part. SCILLC is an Equal Opportunity/Affirmative Action Employer. This literature is subject to all applicable copyright laws and is not for resale in any manner.

### PUBLICATION ORDERING INFORMATION

**LITERATURE FULFILLMENT:**  
 Literature Distribution Center for ON Semiconductor  
 P.O. Box 5163, Denver, Colorado 80217 USA  
**Phone:** 303-675-2175 or 800-344-3860 Toll Free USA/Canada  
**Fax:** 303-675-2176 or 800-344-3867 Toll Free USA/Canada  
**Email:** [orderlit@onsemi.com](mailto:orderlit@onsemi.com)

**N. American Technical Support:** 800-282-9855 Toll Free  
 USA/Canada  
**Europe, Middle East and Africa Technical Support:**  
 Phone: 421 33 790 2910  
**Japan Customer Focus Center**  
 Phone: 81-3-5817-1050

**ON Semiconductor Website:** [www.onsemi.com](http://www.onsemi.com)  
**Order Literature:** <http://www.onsemi.com/orderlit>

For additional information, please contact your local Sales Representative