

SD7780-5

REVISIONS	
ISSUE	CHANGES
0	ER 38895 JLA 07/23/03
1	CN 39090 E JLA 05/07/04
2	CN 39197 C JLA 12/07/04
3	CN 39251 C JLA 03/21/05
4	CN 39662 C DCT 10/12/6
F	ER 6174 BAM 01/18/08
G	ER 14290 PSM 03/16/09

CUSTOMER SALES DRAWING

SCALE 2:1	
APPROX SURFACE AREA	
USED ON	
REF:	
HIGH DEFINITION, DUAL VIDEO JACK STD SIZE (TERMINATED)	
DRAWN JLA	DATE 07/23/03
DESIGN JLA	DATE 07/23/03
APPR.	DATE
<b>KINGS</b> by WINCHESTER ELECTRONICS	Winchester Electronics 62 Barnes Industrial Road North Wallingford, CT 06492
B	SIZE

- NOTES:
- INTERFACE PER MIL-STD-348, FIG. 301-2 (AS APPLICABLE).
  - MATERIALS:  
 BODY: ZINC (ZAMACK)  
 CONTACTS: BER. COPPER, ASTM-B-196  
 INSULATING MATERIALS: ZYTEL, DELRIN & TEFLON, ASTM-D-4894  
 HARDWARE: STAINLESS STEEL  
 ALL OTHER METAL PARTS: BRASS, ASTM-B16
  - FINISHES:  
 CAP & CONTACTS: HARD GOLD PLATE PER ASTM-B488 OVER NICKEL PLATE PER SAE-AMS-QQ-N-290.  
 HARDWARE: PASSIVATE PER QQ-P-35  
 ALL OTHER METAL PARTS: NICKEL PER QQ-N-290
  - MECHANICAL CHARACTERISTICS: 50,000 LIFE CYCLES MIN.
  - ELECTRICAL CHARACTERISTICS:  
 IMPEDANCE: 75 OHMS  
 FREQUENCY RANGE: DC TO 3.5 GHz.  
 RETURN LOSS (NORMAL THRU MODE):  
 UP TO 1.5 GHz, <-23 dB.  
 UP TO 3.5 GHz, <-10 dB.
  - COMPLIANT TO SMPTE 424M (3G-SDI) SPECIFICATION.

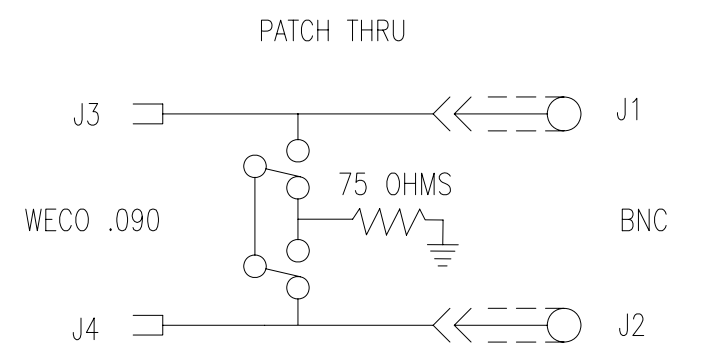
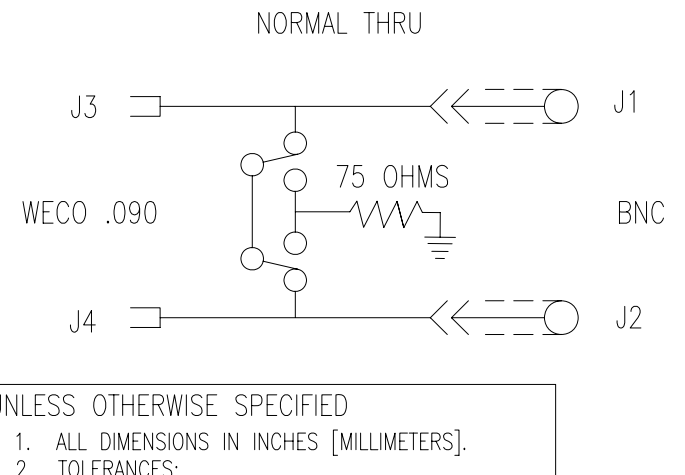

TERMINATED (RESISTOR BETWEEN TERMINAL & GROUND)

UNLESS OTHERWISE SPECIFIED

- ALL DIMENSIONS IN INCHES [MILLIMETERS].
- TOLERANCES:  
 .XXX ±.004 .XX ±.010  
 [.XXX ±.10] [.XX ±.25]  
 FRACTIONS: X/Y ±.010 [.25] ANGLES: ± 1°  
 ★ CRITICAL DIMENSIONS

SD7780-5