

W-6137EVAL1 EVALUATION BOARD FOR W-6137 WHITE LED DRIVER

Denisa Stefan, Applications Engineer

INTRODUCTION

This document describes the W-6137EVAL1 Evaluation Board for the COPAL ELECTRONICS W-6137 white LED driver. The functionality and major parameters of the W-6137 can be evaluated with the W-6137EVAL1 board.

The W-6137 is a CMOS constant-current DC/DC converter that has been designed to drive with high efficiency white or other high brightness LEDs. The device drives up to 5 white LEDs in series. A single external resistor sets the LED current between 5mA and 40 mA. LED current can be adjusted using either a pulse width modulated (PWM) signal or a DC voltage. Detailed descriptions and electrical characteristics are in the W-6137 data sheet.

W-6137EVAL1 BOARD HARDWARE

The evaluation board contains a W-6137 DC-DC boost converter and an array of white LEDs. As configured, the board circuit is set to drive up to 5 white LEDs in series. The user can chose to connect the W-6137 output to the on board LEDs string or to an external LEDs string from an application. The boards are populated with 3 white LEDs in series connected to the W-6137 output by J3 jumper shunt connector.

The board layout provides also the option to connect a different number of LEDs, 2, 4 or 5, using a jumper shunt for one of the J2, J4 or J5 connectors. The board schematic is shown in Figure 1.

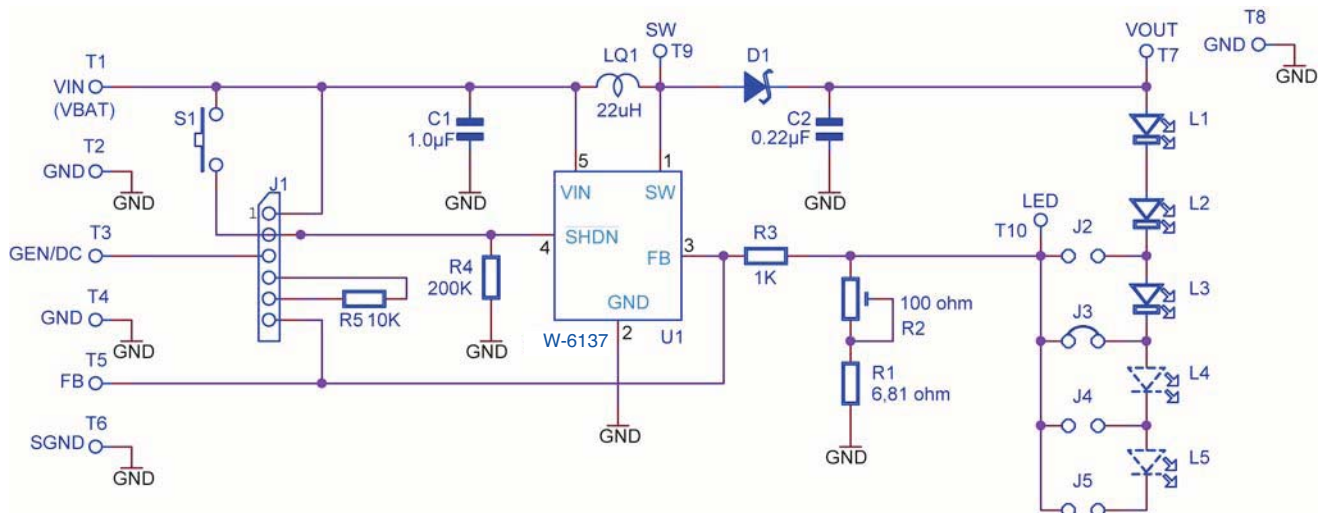

Figure 1. W-6137EVAL1 Board Schematic

The board is powered from an external voltage applied to the VIN (T1) pad or optional from an attached 3V battery (2 x 1.5V AA). The circuit is delivered with the jumper shunt on the J3 connector, which connects the 3 LEDs string available on board to the W-6137 output.

The user can connect his own white LEDs between VOUT (T7) and LED (T10) test points, with no jumper shunt set to any of J2 to J5 connectors.

The LED current is set through the external resistors connected to the FB pin (R1, R2). Using the variable resistor R2, the LED current can be set from 3mA to 40mA. Most white LEDs are driven at a maximum current between 15mA and 20mA to ensure a pure “white” light.

The board also demonstrates the W-6137 shutdown mode and LED brightness control by using an external PWM signal or DC voltage. Resistor R3 and R5 (R5 – soldered on board by the user) are used to adjust the LED current using the dimming control with an external applied DC voltage on the FB pin. The ON/OFF operation and dimming control can be selected using the jumper options for the J1 connector.

Test points T1 to T10 are available to apply the external voltages/signal generator or to measure the output voltages / signals provided by W-6137.

The component placement is shown in Figure 2. Table 1 presents the component list for this evaluation board.

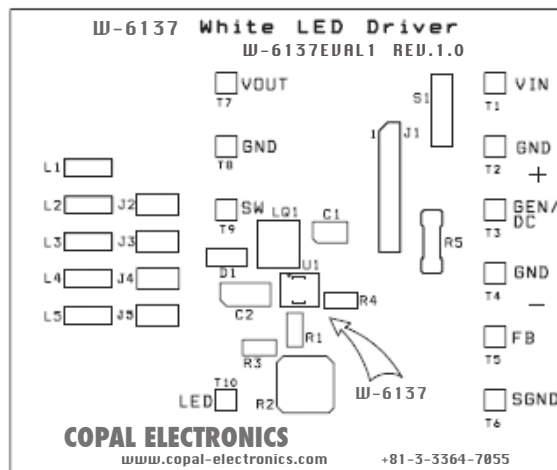

Figure 2. W-6137EVAL1 Board

Table 1. W-6137EVAL1 Board List of Components

Name	Manufacturer	Description	Part Number	Units
U1	COPAL	CMOS White LED Driver, TSOT23 - 5pin	W-6137TS	1
C1 (*)	Murata	Ceramic Capacitor 1.0uF/ 10V, X5R, Size 0805	GRM219R61A105KC01D (Digi-Key 490-1702-1-ND)	1
C2	Taiyo Yuden (or Kemet)	Ceramic Capacitor 0.22uF / 50V, X5R(X7R)	(C1206C224K5RACTU)	1
L1	Murata	Inductor 22uH, low DCR, 250 mA	LQH32CN220K	1
D1	Zetex	Schottky Diode, Low VF, high current, SOD-323	ZHCS400CT-ND	1
R1	Yageo	SMT Resistor 1/16W, 6.81 ohm, 0603	Digi-Key 311-6.81HCT-ND	1
R2	COPAL	Cermet Trimmer 100 ohm	CT-6EP 100Ω (101)	1
R3	Yageo	SMT Resistor 1/16W, 1.0 Kohm, 0603	Digi-Key 311-1.0KHCT-ND	
R4	Yageo	SMT Resistor 1/16W, 200 Kohm, 0603	Digi-Key 311-200KHCT-ND	1
R5	Yageo	Metal Film Resistor 1/16W, 10 Kohm (not soldered on board)	Digi-Key 10.0KXBK-ND	1
L1 to L3	Nichia	White LED, SMT	NSCW100 or NSCW335	3
L4, L5	Nichia	White LED, SMT (optional - not soldered on board)	NSCW100 or NSCW335	
J1		6-pin Header Connector, 0.1", Single Strip	Digi_Key S1012-06-ND (or equiv)	1
J3		2-pin Header Connector, 0.1", Single Strip	Digi_Key S1012-02-ND (or equiv)	1
J2, J4, J5		2-pin Header Connector, 0.1", Single Strip (not soldered on board)	Digi_Key S1012-02-ND (or equiv)	
S1	E-Switch	Momentary Contact Switch, SPST (on)-off	TL1100F160Q (or equiv)	1
T1 to T10	Mil-Max	Pin Receptacle (Test Points)	#0149-0-15-01-30-14-04-0 (or equiv)	10

* Note: When driving more than 3 LEDs, an input capacitor (C1) of 4.7uF is recommended.

W-6137 EVALUATION

The W-6137EVAL1 gives the user a way to evaluate the W-6137 in a typical application of driving multiple LEDs.

The board is provided with 3 white LEDs in series connected to the W-6137 output.

The following steps are an example of how the user can evaluate the W-6137 white LED driver.

1) Driving 3 LEDs in series and Shutdown Mode

- a) Connect the 3-LEDs string to the W-6137 output using a jumper shunt on J3 header-pin connector (default configuration).

- b) Set the R2 potentiometer to the middle position.
- c) Apply the external voltage supply, V_{ext} ($3.0V < V_{IN} < 5V$) between VIN (T1) and GND (T2).
- d) The W-6137 is in the **shutdown mode** (SHDN pin is connected to GND) if the J1 connector is not jumpered (or S1 switch is not pressed).
 - Connect a current meter between V_{ext} and VIN pad to measure the shutdown current: $I_{SD} \ll 1\mu A$
 - In this mode of operation the LEDs are disconnected from the output: LEDs are OFF.
- e) Connect SHDN pin of the W-6137 to VIN using a jumper shunt between Pin #1 and Pin #2 of J1 connector (or press the S1 switch).
 - Observe that LEDs are ON.

2) LED Current Evaluation

a) Programming LED current

LED current is programmed using the external resistors, $R_{SET} = R1 + R2$, connected to the FB pin. The voltage at the FB pin is internally regulated to the value $V_{FB} = 300mV \pm 15 mV$.

The current into the LED pin can be set according to the following equation:

$$I_{LED} (mA) = V_{FB} (mV) / R_{SET}(ohm) = V_{FB} / (R1 + R2).$$

- Set the input voltage: ex. $V_{IN} = 3.6V$.
- Disconnect the jumper from the J3 connector and insert a current meter between these pins to monitor the LED current, I_{LED} .
- Rotate the potentiometer R2 and observe the I_{LED} value on the current meter. The current can be adjusted between 3mA and 40mA, approximately. Various LED current values and the associated R_{SET} values are listed below:

I_{LED} (mA)	R_{SET} (ohm)
5	59.1
10	29.8
15	20
20	15
25	12
30	10

- Monitor the voltage on FB (T5), VOUT (T7), and SW (T9).
- Verify the internal switch frequency ($f_{SW} = 1.0MHz$ – typically) using a scope probe connected on SW (T9) test point (GND = T8).

Figure 3 shows the internal switch output, VSW (DC coupled, 5V/div) and the regulated voltage on FB pin, V_{FB} (DC, 500mV/div) for $V_{IN} = 3.6V$, $I_{LED} = 20 mA$, 3 LEDs in series connected to the W-6137 output.

Figure 4 shows the VOUT (CH2, AC coupled, 100mV/div) against VSW (CH1).

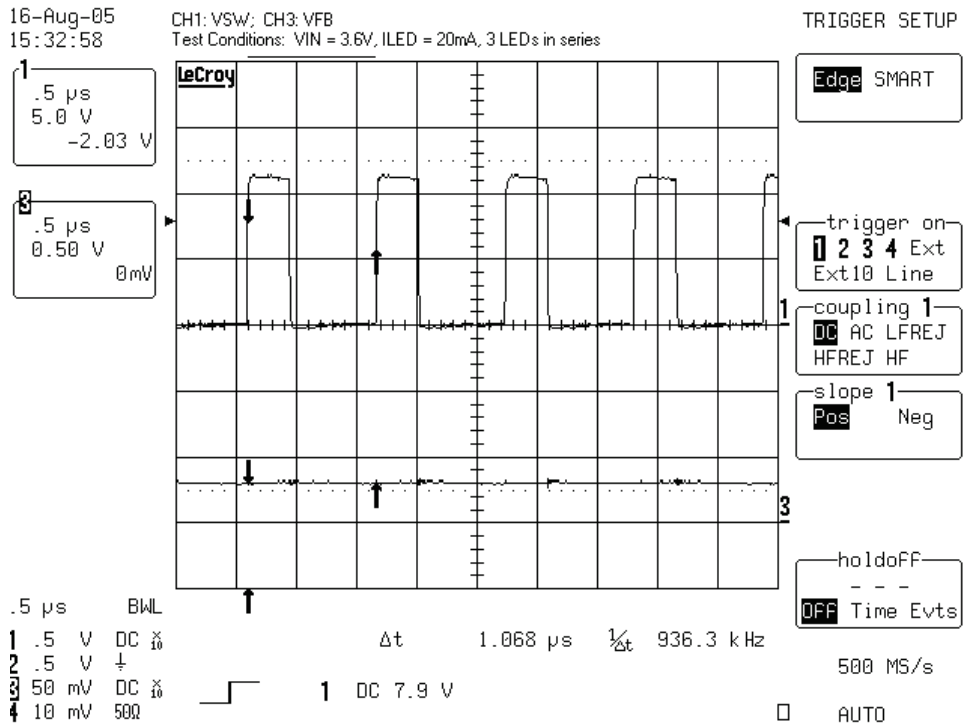

Figure 3. Internal Switch Output and Regulated VFB Voltage Waveforms (ILED = 20mA, VIN = 3.6V)

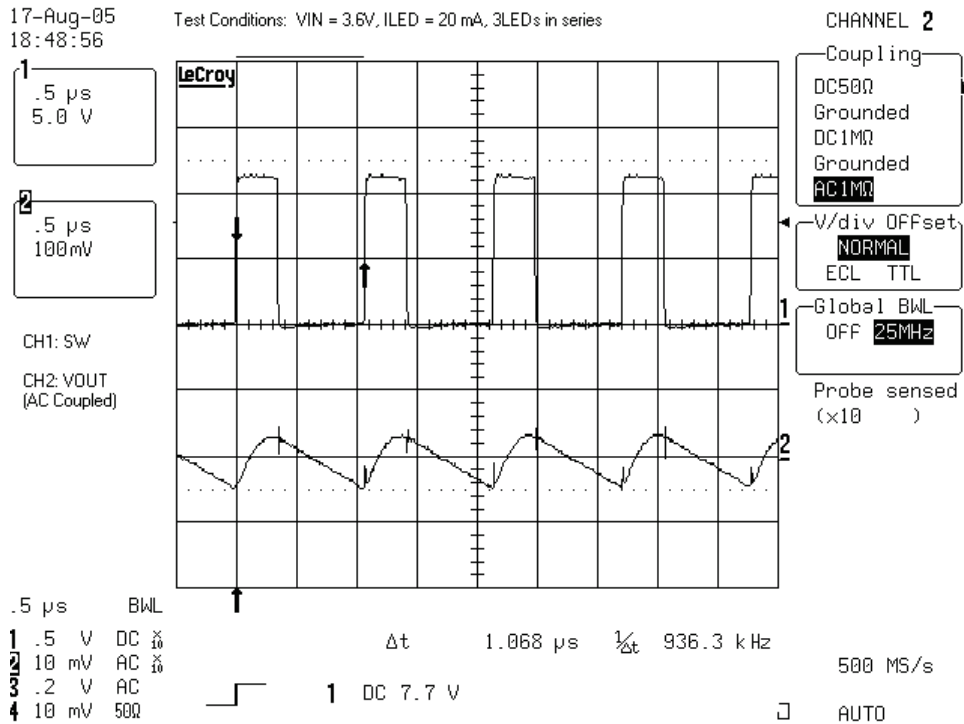
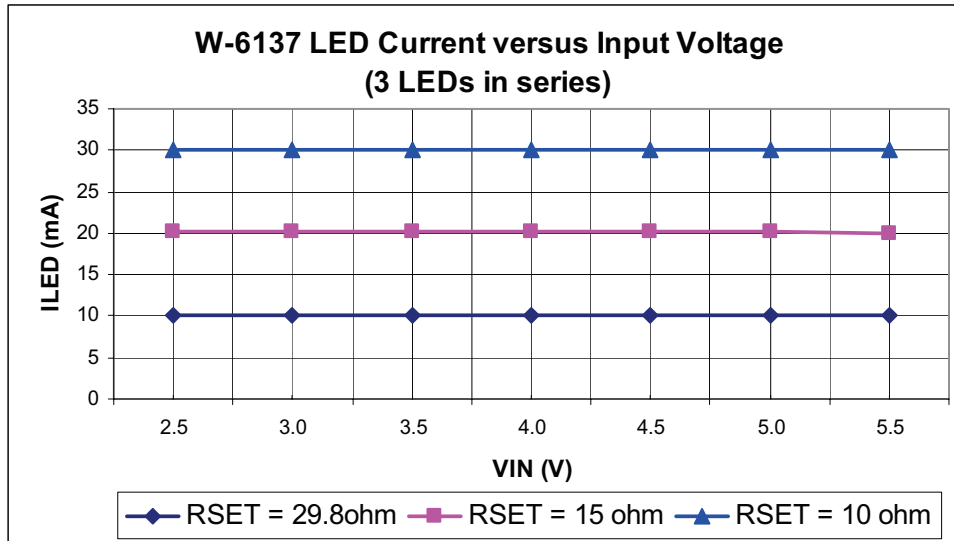

Figure 4. Internal Switch and Output Voltage Waveforms (ILED = 20 mA, VIN = 3.6V)

b) Evaluating LED current regulation versus the input voltage, VIN.

- Set the ILED to a programmed value using the R2 potentiometer (i.e. 10mA, 20mA, 30mA for VIN = 3.6V).
- For any ILED value vary the VIN voltage between 2.5V and 5.5V.
- Observe the value of ILED measured by the current meter. Figure 5 presents the ILED current versus VIN.



Note: RSET = R1 + R2

Figure 5. LED current Line Regulation

3) Efficiency Evaluation

The efficiency is evaluated according to the following equation:

$$\text{Efficiency \%} = 100 \times (\text{ILED} \times \sum \text{Vfi}) / (\text{IIN} \times \text{VIN})$$

where $\sum \text{Vfi} = \text{VOUT} - \text{VLED}$, VLED is the voltage measured at LED (T10) test point.

- a) Insert a current meter, CM1, between input supply voltage, Vext, and VIN pad to monitor the input current, IIN.
- b) Set the input voltage for VIN = 3.6V.
- c) Adjust the R2 potentiometer for the ILED = 5mA. Observe the ILED current on the meter, CM2, inserted at J3 connector.
- d) Measure the IIN current on CM1.
- e) Monitor the output voltage on VOUT (T7) and VLED voltage on LED (T10) test points.
- f) Repeat steps c) to e) for ILED = 10mA, 15mA, 20mA, 25mA and 30 mA.

Figure 6 presents the efficiency measured for 2 values of input voltage, VIN = 3.6V and VIN = 4.2V, with 3 LEDs in series connected to the W-6137 output. The efficiency is over 87% for the recommended LED current levels of 15mA to 20mA that ensure a pure “white” light.

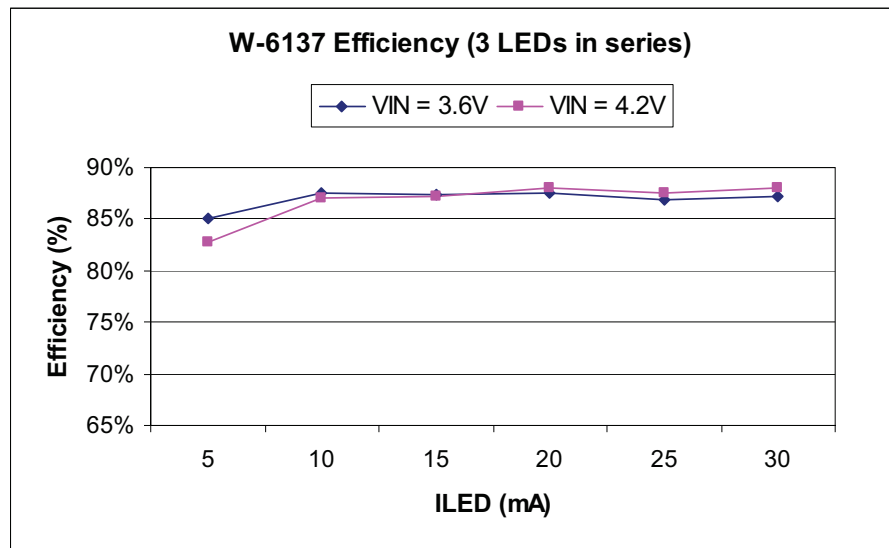

Figure 6. W-6137 Efficiency driving 3 LEDs in series.

4) Dimming Control

The LED brightness control can be accomplished by using a PWM signal applied to the SHDN pin or to the FB pin. The other method is to use a variable DC voltage applied through a resistor to FB pin.

a) Dimming using a PWM signal on the SHDN pin.

The LEDs are turned off and on at the PWM frequency. The average current changes with the duty cycle. Increasing the duty cycle will increase the LED brightness. The peak current value sets the light spectrum.

- Connect the jumper shunt between Pin #2 and Pin #3 of the J1 connector.
- Apply a pulse signal generator to the GEN/DC (T3) pad: Frequency = 200Hz to 2 KHz; Amplitude 0V to 3V; VIN = 3.6V.
- Modify the duty cycle between 0% and 100%.
- Observe the average current through LEDs measured by a current meter inserted at J3 connector. For 0% duty cycle, the ILED will be off (ILED = 0mA); At the maximum duty cycle, the LED will be driven at the maximum current set by the R2 potentiometer. The LED current can be also monitored using a current probe and compared with the signal applied on SHDN pin.
- Monitor the FB voltage compared with the PWM signal applied on SHDN input.

Figure 7 shows the LED current measured with a current probe (CH2: ILED 10mA/div) using a PWM signal applied to the SHDN pin (CH1). The frequency of the PWM signal is 2 KHz approximately.

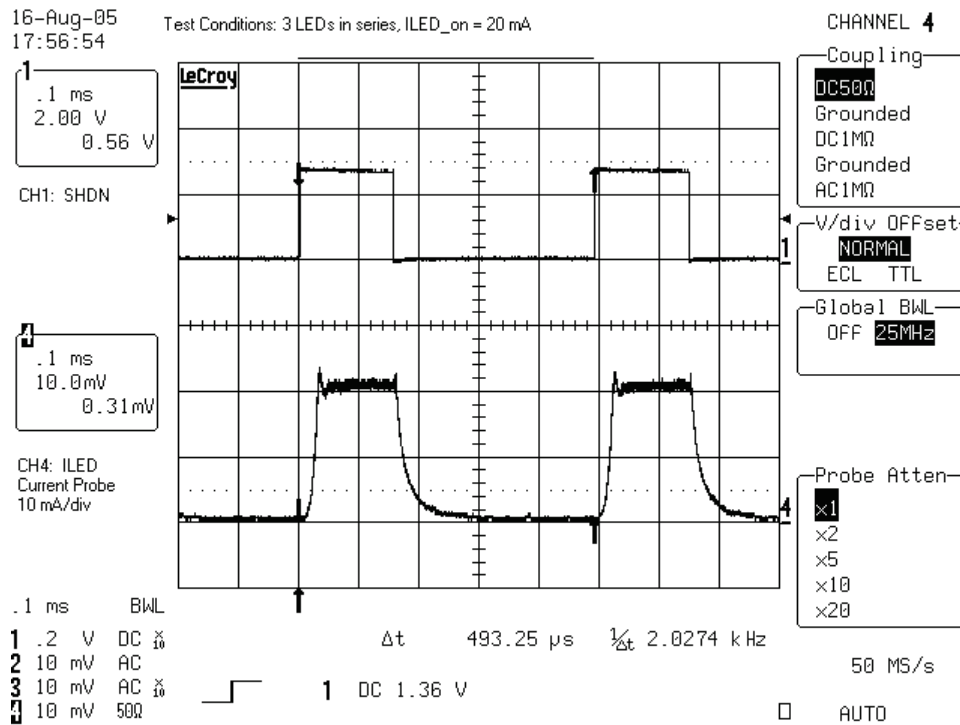

Figure 7. LED Current Waveform with PWM

b) Dimming using a DC voltage applied to the FB pin

A variable external DC voltage can be applied on FB pin to adjust the LED current. As the DC voltage is increased, the voltage drop on resistor R3 is increased and the voltage drop on RSET = R1+R2 is decreased, thus the LED current decreases. The external DC voltage is applied to FB pin through a series resistor, R5, which sets the maximum DC voltage.

Also, a filtered PWM signal can be considered as a variable DC voltage.

- Connect the SHDN pin to VIN: jumper shunt between Pin #1 and Pin #2 of J1 connector.
- Set the ILED current (i.e. ILED_MAX = 20 mA).
- Connect the GEN/DC to FB pin through R5 resistor using one jumper between Pin #3 and Pin #4 and another jumper shunt between Pin #5 and Pin #6 of J1 connector.
- Apply the variable DC voltage between GEN/DC (T3) and GND (T4).
- Increase the DC voltage value (from 0V to VMAX = 3.2V).
- Observe the ILED current decreases from the ILED MAX (20mA – previous set) to ILED MIN (0mA for VMAX = 3.2V with the existing resistors values, R3 = 1Kohm, R5 = 10Kohm).