



Package: QFN, 2mm x 2mm x 0.55mm



Features

- Low Frequency to 3.8GHz Operation
- Low Insertion Loss, Typ. 0.3dB at 1GHz
- Very High Isolation, Typ. 42dB at 1GHz
- High Linearity, IIP2 Typ. 129dBm
- Direct Connection to V_{BATT}
- Compatible with Low Voltage Logic (V_{HIGH} Minimum = 1.3V)
- No External DC Blocking Capacitors Required on RF Paths Unless DC is applied Externally
- 2kV HBM Rating on All Ports

Applications

- SV-LTE, WCDMA, GSM
- Post PA Switching
- General Purpose Switching Applications

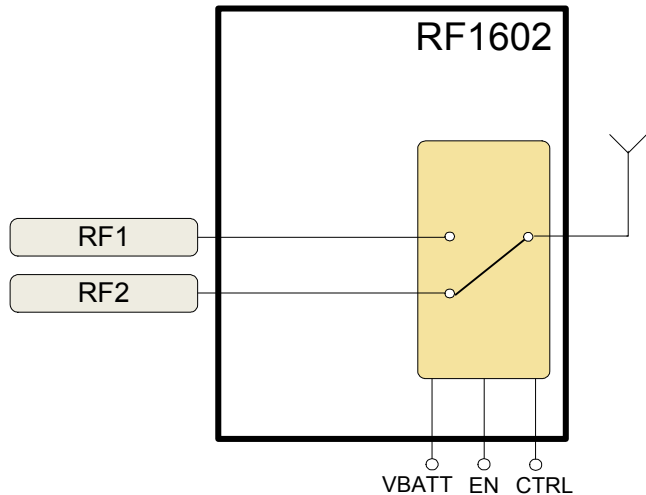

Functional Block Diagram

Product Description

The RF1602 is a single-pole dual-throw (SPDT) switch designed for switching applications requiring very low insertion loss and high power handling capability coupled with minimal DC power consumption. The excellent linearity performance achieved by the RF1602 makes it ideal for use in SV-LTE, WCDMA, and CDMA applications. The RF1602 offers very high isolation between RF ports providing greater separation between transmit and receive paths. The RF1602 is packaged in a very compact 2mm x 2mm x 0.55mm 12-Pin QFN package.

Ordering Information

RF1602 SB	Sample Bag (5 pieces)
RF1602 SQ	25 Piece Sample Bag
RF1602 SR	100 Pieces 7" Reel
RF1602 TR7	2500 Pices 7" Reel
RF1602PCK-410	Fully Assembled Evaluation Board (including 5 loose piece samples)

Absolute Maximum Ratings

Parameter	Rating	Unit
Maximum V_{BATT}	6.0	V
Maximum EN	3.0	V
Maximum CTRL	3.0	V
Maximum Power Handling (6:1 VSWR, Temp = 25 °C)	+36	dBm
Operating Temperature	-40 to +85	°C
Storage Temperature	-40 to +125	°C



Caution! ESD sensitive device.

Exceeding any one or a combination of the Absolute Maximum Rating conditions may cause permanent damage to the device. Extended application of Absolute Maximum Rating conditions to the device may reduce device reliability. Specified typical performance or functional operation of the device under Absolute Maximum Rating conditions is not implied.

The information in this publication is believed to be accurate and reliable. However, no responsibility is assumed by RF Micro Devices, Inc. ("RFMD") for its use, nor for any infringement of patents, or other rights of third parties, resulting from its use. No license is granted by implication or otherwise under any patent or patent rights of RFMD. RFMD reserves the right to change component circuitry, recommended application circuitry and specifications at any time without prior notice.



RFMD Green: RoHS compliant per EU Directive 2002/95/EC, halogen free per IEC 61249-2-21, < 1000 ppm each of antimony trioxide in polymeric materials and red phosphorus as a flame retardant, and <2% antimony in solder.

Nominal Operating Parameters

Parameter	Specification			Unit	Condition
	Min.	Typ.	Max.		
(All Nominal Test Conditions Unless Otherwise Stated) $V_{BATT} = 3.5V$, Temperature = 25 °C, All RF ports terminated in 50Ω					
Insertion Loss					
RF1 to ANT, RF2 to ANT		0.30	0.40	dB	400MHz to 1GHz
		0.30	0.45	dB	1.0GHz to 2.0GHz
		0.35	0.50	dB	2.0GHz to 2.5GHz
		0.40	0.55	dB	2.5GHz to 3.5GHz
		0.40	0.60	dB	3.5GHz to 3.8GHz
Isolation					
RF1 to RF2, RF2 to RF1	37	42		dB	400MHz to 1GHz
	31	34		dB	1.0GHz to 2.0GHz
	30	32		dB	2.0GHz to 2.5GHz
	25	29		dB	2.5GHz to 3.5GHz
	24	29		dB	3.5GHz to 3.8GHz
RF Port Return Loss					
ANT, RF1, RF2	10	15		dB	400MHz to 3.8GHz
900MHz Harmonics					
Second Harmonic		-95	-75	dBc	$P_{IN} = 35dBm$
Third Harmonic		-90	-75	dBc	
1800MHz Harmonics					
Second Harmonic		-95	-75	dBc	$P_{IN} = 33dBm$
Third Harmonic		-90	-75	dBc	
IIP2					
RF1, RF2, ANT (Cell)	122	129		dBm	Tone 1: 836.5MHz at +26dBm Tone 2: 1718MHz at -20dBm Receive Freq: 881.5MHz
RF1, RF2, ANT (AWS)	122	129		dBm	Tone 1: 1732.5MHz at +26dBm Tone 2: 3865MHz at -20dBm Receive Freq: 2132.5MHz
RF1, RF2, ANT (PCS)	122	129		dBm	Tone 1: 1880MHz at +26dBm Tone 2: 3840MHz at -20dBm Receive Freq: 1960MHz
RF1, RF2, ANT (IMT)	122	129		dBm	Tone 1: 1950MHz at +26dBm Tone 2: 4090MHz at -20dBm Receive Freq: 2140MHz

Parameter	Specification			Unit	Condition
	Min.	Typ.	Max.		
(All Nominal Test Conditions Unless Otherwise Stated) $V_{BATT} = 3.5V$, Temperature = 25 °C, All RF ports terminated in 50Ω					
IIP3 SV-LTE					
RF1, RF2, ANT (Cell)		83		dBm	Tone 1: 786MHz at +23dBm Tone 2: 825MHz at +14dBm Receive Freq: 747MHz
RF1, RF2, ANT (Cell)		80		dBm	Tone 1: 782MHz at +23dBm Tone 2: 827MHz at +14dBm Receive Freq: 872MHz
IIP3					
RF1, RF2, ANT (Cell)	70	75		dBm	Tone 1: 836.5MHz at +26dBm Tone 2: 791.5MHz at -20dBm Receive Freq: 881.5MHz
RF1, RF2, ANT (IMT)	70	75		dBm	Tone 1: 1950MHz at +23dBm Tone 2: 1760MHz at -20dBm Receive Freq: 2140MHz
Max Operating Power					
			36	dBm	50Ω, Temp = 25°C
			35	dBm	VSWR = 6:1, Temp = -40° to +85°C
Supply and Control Signal Characteristics					
Supply Voltage, V_{BATT}	2.7	3.5	4.6	V	
Supply Current, V_{BATT}					
EN = HIGH		100	200	μA	
EN = LOW		14	20	μA	
Control Voltage (EN, CTRL)					
V_{HIGH}	1.3	1.8	2.7	V	
V_{LOW}		0	0.45	V	
Control Current					
I_{HIGH}		2.5	5	μA	
I_{LOW}		1	3	μA	
Switching Time					
Switching Speed ON		2	5	μs	All combination; 50% control to 90% RF ON
Switching Speed RF OFF		2	5	μs	All combinations; 50% control to 10% RF OFF
Start Up Time from Shutdown			5	μs	Maximum set up time for the switch to reach fully compliant operation
Turn-on Time		5	20	μs	Time from V_{BATT} 50% of operational voltage to RF signal at 90%

Power Up/Power Down and Operational Controls for the RF1602

Scenario 1	Sequence for Power UP and Power DOWN from the phone battery or supply that is connected to RF1602 V _{BATT} pin.
Power UP	Turn on V _{BATT} (supply), then EN, then CTRL, then (20μs or greater), apply RF signal
Power DOWN	Turn off RF signal, then CTRL, then EN, turn off V _{BATT} (supply)
Scenario 2	Sequence for going in and out of a shutdown mode, keeping the V _{BATT} or supply on, but disabling/enabling the RF1602 by the EN pin.
Power UP	Turn-on EN (enable), then CTRL, then (5μs or greater), turn-on RF signal
Power DOWN	Turn-off RF signal, then CTRL, then EN (disable)
Scenario 3	When changing switch positions between RF1 and RF2, no RF signal should be applied to any RF port while the CTRL is changing states
Switching Ports	Turn-off RF signal, then change CTRL state, then (5μs or greater), turn-on RF signal

Pin Names and Description

Pin	Function	Description
1	GND	Ground.
2	ANT	Single ended RF port.
3	GND	Ground.
4	GND	Ground.
5	RF1	Single ended RF port.
6	GND	Ground.
7	CTRL	Switch logic control input.
8	EN	Switch logic control input, shutdown for low leakage current.
9	VBATT	Supply voltage from battery.
10	GND	Ground.
11	RF2	Single ended RF port.
12	GND	Ground.
13	Package Base	Ground.

Pin Out

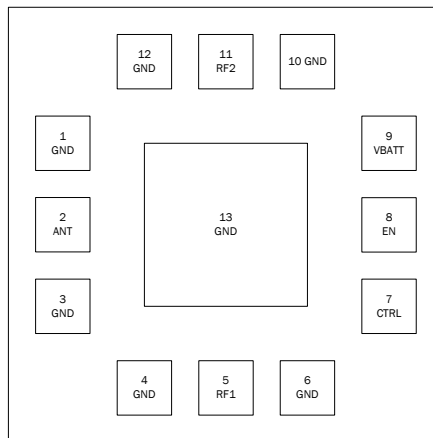

Top View

Control Logic

State	V _{BATT}	CTRL	EN	RF Path
1	2.7V to 4.6V	V _{HIGH}	V _{HIGH}	ANT-RF2
2	2.7V to 4.6V	V _{LOW}	V _{HIGH}	ANT-RF1
Shutdown	2.7V to 4.6V	Don't Care	V _{LOW}	Shutdown

The switch is operable in 3 states. The switch is designed for two modes: active and shutdown. Assuming VBATT is always between 2.7V and 4.6V the switch is controlled by the EN voltage. When EN is HIGH the switch is active and when EN is LOW the switch is in standby mode.

Package Drawing

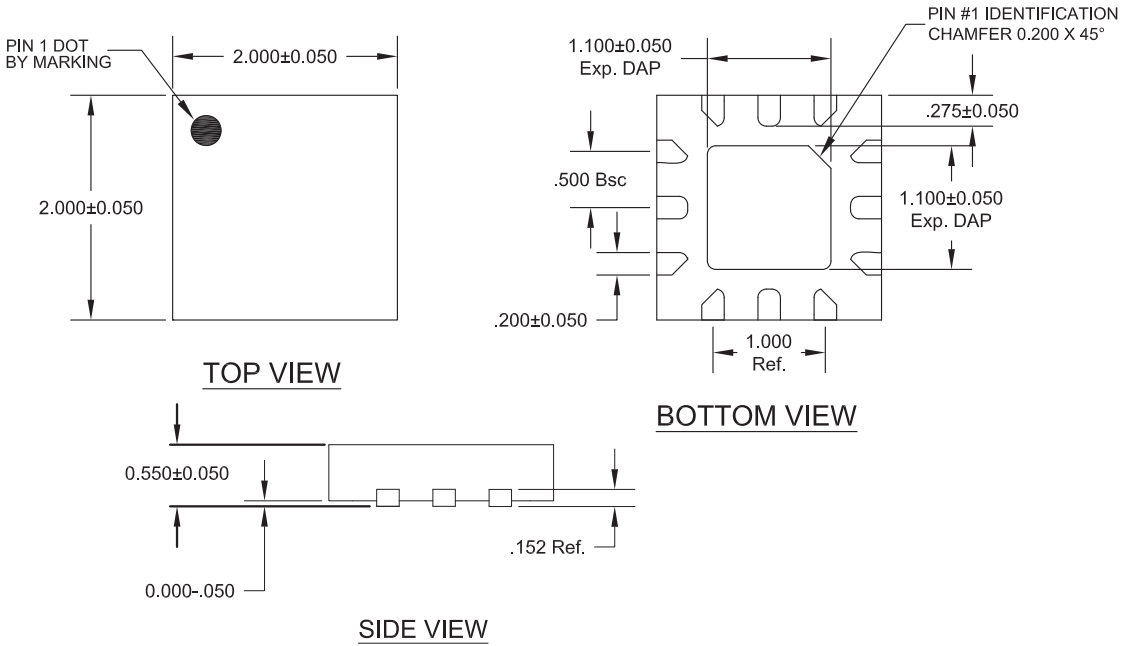

PCB Surface Finish

The PCB surface finish used for RFMD's qualification process is electroless nickel, immersion gold. Typical thickness is 3µinch to 8µinch gold over 180µinch nickel.

PCB Land Pattern Recommendation

PCB land patterns for RFMD components are based on IPC-7351 standards and RFMD empirical data. The pad pattern shown has been developed and tested for optimized assembly at RFMD. The PCB land pattern has been developed to accommodate lead and package tolerances. Since surface mount processes vary from company to company, careful process development is recommended.

PCB Metal Land and Solder Mask Pattern

- A = 0.230 x 0.402 (mm) Typ
- B = 0.402 x 0.230 (mm) Typ
- C = 0.230 x 0.402 (mm) Rounded Rectangle 0.058 Corner Radius
- D = 0.402 x 0.230 (mm) Rounded Rectangle 0.058 Corner Radius
- E = 1.040 x 1.040 (mm)

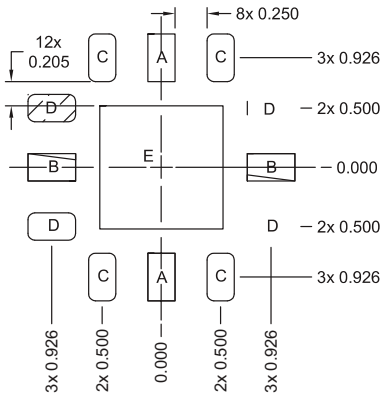

PCB METAL PATTERN

- A = 0.207 x 0.362 (mm)
- B = 0.362 x 0.207 (mm)
- C = 0.207 x 0.362 (mm) Rounded Rectangle 0.052 Corner Radius
- D = 0.362 x 0.207 (mm) Rounded Rectangle 0.052 Corner Radius
- E = 0.936 x 0.936 (mm)

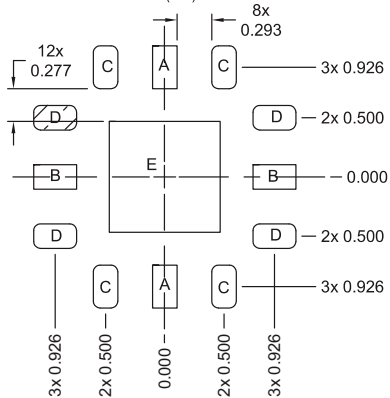

PCB STENCIL PATTERN

- A = 0.332 x 0.504 (mm) Typ
- B = 0.504 x 0.332 (mm) Typ
- C = 0.332 x 0.504 (mm) Rounded Rectangle 0.109 Corner Radius
- D = 0.504 x 0.332 (mm) Rounded Rectangle 0.109 Corner Radius
- E = 1.142 x 1.142 (mm)

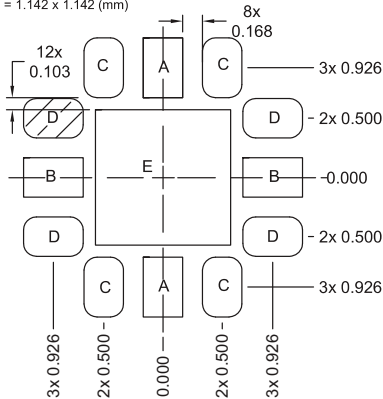

PCB SOLDER MASK PATTERN

Shaded are represents Pin 1 location.

Evaluation Board Schematic

