



General Description

The SLG55566/SLG55566A is a USB device that combines high speed USB switches with a USB host charger (dedicated charger) identification circuit. The device supports both the latest USB Battery Charging Specification Revision 1.2 including data contact detection and a set resistor bias for Apple compliant devices as well as legacy USB D+/D- short detection using data line pull-up.

Features

- High Speed USB Switching
- Low 4.0pF (typ) On Capacitance
- Low 4.0Ω (typ) On Resistance
- Low 0.5Ω (typ) On Resistance Flatness
- 2.8V to 5.5V Supply Range
- Low 8μA (typ) Supply Current
- Automatic Current-Limit Switch Control
- Automatic USB Charger Identification Circuit
- USB Battery Charging Specification 1.2 compliant
- Pb-Free / RoHS Compliant
- Halogen-Free
- TDFN-8 Package

Block Diagram

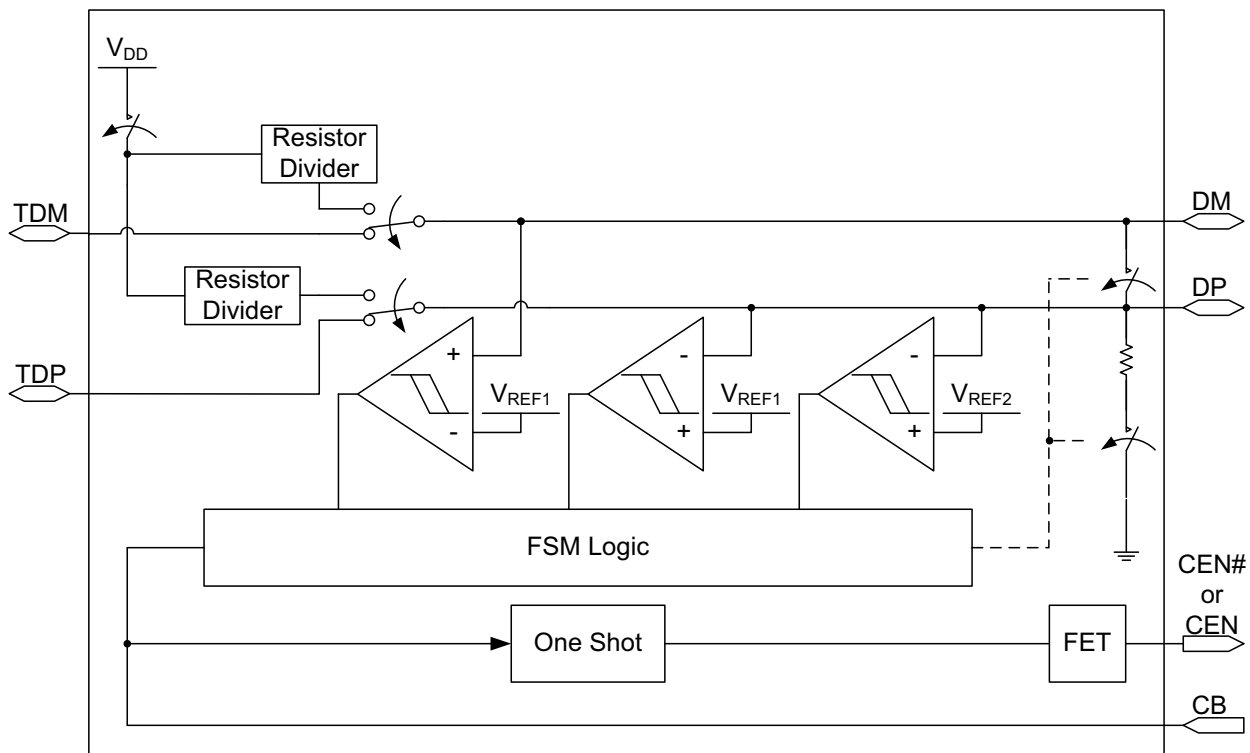

Pin Configuration - SLG55566

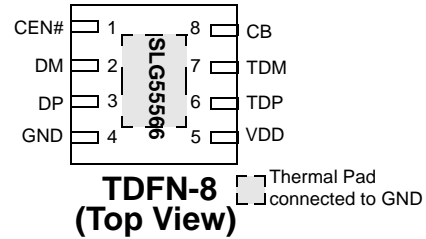

Pin Configuration - SLG55566A

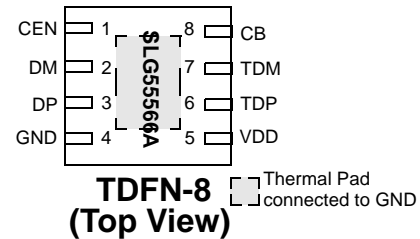



Pin Description - SLG55566

Pin #	Name	Type	Description
1	CEN#	Output	P-FET Open Drain Output. Current Limit Switch (CLS) Control Output. CB changes from 0 to 1 or 1 to 0. CEN# will be high for 1 second (typ)
2	DM	Input/Output	USB Connector D-
3	DP	Input/Output	USB Connector D+
4	GND	GND	Ground
5	VDD	PWR	Power Supply. Connect a 0.1 μ F capacitor between VDD and GND as close as possible to the device.
6	TDP	Input/Output	Host USB Transceiver D+ Connection
7	TDM	Input/Output	Host USB Transceiver D- Connection
8	CB	Input	Switch Control Bit 0 = autodetection charger identification active 1 = pass-through mode active, DP/DM connected to TDP/TDM
9	Thermal Pad	GND	Ground

Pin Description - SLG55566A

Pin #	Name	Type	Description
1	CEN	Output	N-FET Open Drain Output. Current Limit Switch (CLS) Control Output. CB changes from 0 to 1 or 1 to 0. CEN will be low for 1 second (typ)
2	DM	Input/Output	USB Connector D-
3	DP	Input/Output	USB Connector D+
4	GND	GND	Ground
5	VDD	PWR	Power Supply. Connect a 0.1 μ F capacitor between VDD and GND as close as possible to the device.
6	TDP	Input/Output	Host USB Transceiver D+ Connection
7	TDM	Input/Output	Host USB Transceiver D- Connection
8	CB	Input	Switch Control Bit 0 = autodetection charger identification active 1 = pass-through mode active, DP/DM connected to TDP/TDM
9	Thermal Pad	GND	Ground

Ordering Information

Part Number	Type
SLG55566V	TDFN-8
SLG55566AV	TDFN-8
SLG55566VTR	TDFN-8 - Tape and Reel
SLG55566AVTR	TDFN-8 - Tape and Reel

**Absolute Maximum Conditions**

Parameter	Min.	Max.	Unit
Supply Voltage	-0.3	6.0	V
Continuous Current into any terminal	-30	+30	mA
Continuous Power Dissipation	--	954	mW
Operating Temperature Range	-40	85	°C
Junction Temperature		150	°C
Storage Temperature Range	-65	150	°C
Lead Temperature (Soldering, 10s)		260	°C

Electrical Characteristics - Power Supply

$V_{DD} = 2.8V$ to $5.5V$, $T_A = 25^\circ C$ (unless specified otherwise)

Symbol	Parameter	Condition/Note	Min.	Typ.	Max.	Unit
V_{DD}	Power Supply Range	$V_{CB} > V_{IH}$	2.8	--	5.5	V
		$V_{CB} = 0V$	4.75	--	5.25	V
I_{DD}	Supply Current	$V_{CB} = V_{DD}$, $V_{DD} = 3.3$	--	--	6	μA
		$V_{CB} = V_{DD}$, $V_{DD} = 5.5$	--	--	8	μA
		$V_{CB} = 0V$, $V_{DD} = 4.75$	--	110	145	μA
		$V_{CB} = 0V$, $V_{DD} = 5.25V$	--	120	160	μA
ΔI_{DD}	Supply Current Increase	$0 \leq V_{CB} \leq V_{IL}$ or $V_{IH} \leq V_{CB} \leq V_{DD}$	--	--	2	μA

Electrical Characteristics - Analog Switch

$V_{DD} = 2.8V$ to $5.5V$, $T_A = 25^\circ C$ (unless specified otherwise)

Symbol	Parameter	Condition/Note	Min.	Typ.	Max.	Unit
V_{DP} , V_{DM}	Analog signal Range		0	--	V_{DD}	V
R_{ON}	On Resistance TDP/TDM Switch	$V_{DP} = V_{DM} = -0.4V$ to $0.4V$ $I = 10mA$	--	3.5	--	Ω
		$V_{DP} = V_{DM} = 0V$ to $3.3V$ $V_{DD} = 5.0V$	--	4.0	7	Ω
ΔR_{ON}	On Resistance Match between channels TDP/TDM Switch	$V_{DD} = 5.0V$ $V_{DP} = V_{DM} = 400mV$ $I_{DP} = I_{DM} = 10mA$	--	0.1	--	Ω
R_{FLAT}	On Resistance flatness TDP/TDM Switch	$V_{DD} = 5.0V$ $V_{DP} = V_{DM} = 0V$ to V_{DD} $I_{DP} = I_{DM} = 10mA$	--	0.5	--	Ω
R_{SHORT}	On Resistance of TDP/TDM Short	$V_{CB} = 0V$ $V_{DP} = 1V$ $I_{DP} = I_{DM} = 10mA$	--	50	70	Ω
I_{TDPOFF} , I_{TDMOFF}	Off-Leakage Current	$V_{DD} = 3.6V$ $V_{DP} = V_{DM} = 0.3V$ to $3.3V$ $V_{TDP} = V_{TDM} = 3.3V$ to $0.3V$ $V_{CB} = 0V$	-250	--	250	nA
I_{DPON} , I_{DMON}	Off-Leakage Current	$V_{DD} = 3.6V$ $V_{DP} = V_{DM} = 3.3V$ to $0.3V$ $V_{CB} = V_{DD}$	-250	--	250	nA



Electrical Characteristics - Dynamic Performance

$V_{DD} = 2.8V$ to $5.5V$, $T_A = 25^\circ C$ (unless specified otherwise)

Symbol	Parameter	Condition/Note	Min.	Typ.	Max.	Unit
T_{ON}	Turn On Time	V_{TDP} or $V_{TDM} = 1.5V$ $R_L = 300\Omega$ $C_L = 35pF$	--'	20	100	μs
T_{OFF}	Turn Off Time	V_{TDP} or $V_{TDM} = 1.5V$ $R_L = 300\Omega$ $C_L = 35pF$	--'	1	5	μs
T_{PLH}, T_{PHL}	TDP/TDM Switch Propagation Delay	$R_L = R_S = 50\Omega$	--	60	--	ps
T_{SKEW}	Output Skew	Skew between DP and DM when connected to TDP and TDM $R_L = R_S = 50\Omega$	--	40	--	ps
C_{OFF}	TDP/TDM Off-Capacitance	$f = 1MHz$	--'	2.0	--	pF
C_{ON}	DP/DM On-Capacitance	$f = 240MHz$	--'	4.0	5.5	pF
BW	-3dB Bandwidth	$R_L = R_S = 50\Omega$	--	950	--	MHz
V_{ISO}	Off-Isolation	$V_{TDP}, V_{DP} = 0dBm$ $R_L = R_S = 50\Omega$ $f = 250MHz$	--	-19.5	--	dB
V_{CT}	Crosstalk	$V_{TDP}, V_{DP} = 0dBm$ $R_L = R_S = 50\Omega$ $f = 250MHz$	--	-24.9	--	dB

Electrical Characteristics - Internal Resistors

$V_{DD} = 2.8V$ to $5.5V$, $T_A = 25^\circ C$ (unless specified otherwise)

Symbol	Parameter	Condition/Note	Min.	Typ.	Max.	Unit
R_{PD}	DP/DM Short Pull-down		350	500	700	$k\Omega$
RT_{RP}	RP1/RP2 Ratio		1.485	1.5	1.515	Ratio
R_{RP}	RP1 + RP2 Resistance		93.75	125.0	156.25	$k\Omega$
RT_{RM}	RM1/RM2 Ratio		0.8544	0.863	0.872	Ratio
R_{RM}	RM1 + RM2 Resistance		69.75	93.0	115.18	$k\Omega$

Electrical Characteristics - Logic Input

$V_{DD} = 2.8V$ to $5.5V$, $T_A = 25^\circ C$ (unless specified otherwise)

Symbol	Parameter	Condition/Note	Min.	Typ.	Max.	Unit
V_{IH}	CB Input Logic High		1.4	--	--	V
V_{IL}	CB Input Logic Low		--	--	0.4	V
I_{IN}	CB Input Leakage Current	$V_{DD} = 5.5V$ $0 \leq V_{CB} \leq V_{IL}$ or $V_{IH} \leq V_{CB} \leq V_{DD}$	-1	--	1	μA



Electrical Characteristics - CEN#/CEN Outputs

$V_{DD} = 2.8V$ to $5.5V$, $T_A = 25^\circ C$ (unless specified otherwise)

Symbol	Parameter	Condition/Note	Min.	Typ.	Max.	Unit
T_{VBT}	V_{BUS} Toggle Time	CB = Logic 0 to Logic 1 or Logic 1 to Logic 0	0.5	1	1.5	s
$V_{OH_CEN\#}$	CEN# Output Logic High Voltage	CB = Logic 0 to Logic 1 $I_{SINK} = 2mA$	$V_{DD}-0.4V$	--	--	V
$I_{OUT_CEN\#}$	CEN# Output Leakage Current	$V_{DD} = 5.5V$ $V_{CEN\#} = 0V$ or CEN# deasserted	--	--	1	μA
V_{OL_CEN}	CEN Output Logic Low Voltage	CB = Logic 0 to Logic 1 $I_{SOURCE} = 2mA$	--	--	0.4V	V
I_{OUT_CEN}	CEN Output Leakage Current	$V_{DD} = 5.5V$ $V_{CEN} = 5.5V$ or CEN deasserted	--	--	1	μA

Electrical Characteristics - ESD Protection

$V_{DD} = 2.8V$ to $5.5V$, $T_A = 25^\circ C$ (unless specified otherwise)

Symbol	Parameter	Condition/Note	Min.	Typ.	Max.	Unit
V_{ESD}	ESD Protection Level (DP and DM Only)	Human Body Model	--	± 8	--	kV
V_{ESD}	ESD Protection Level (All other pins)	Human Body Model	--	± 2	--	kV



Package Top Marking System Definition

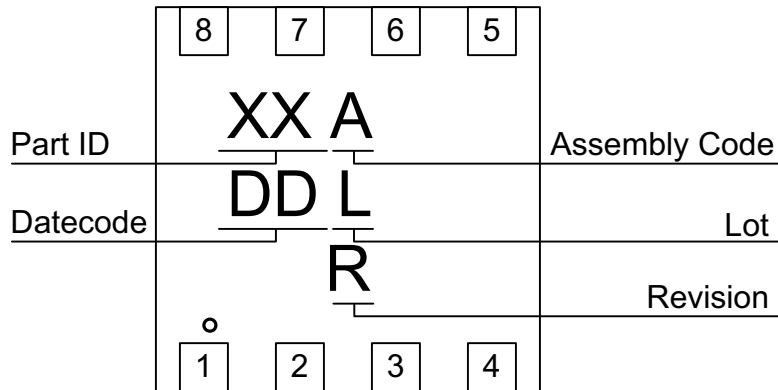

- XX – Part ID Field: identifies the specific device configuration
- A – Assembly Code Field: Assembly Location of the device.
- DD – Date Code Field: Coded date of manufacture
- L – Lot Code: Designates Lot #
- R – Revision Code: Device Revision



Package Drawing and Dimensions
8 Lead TDFN Package

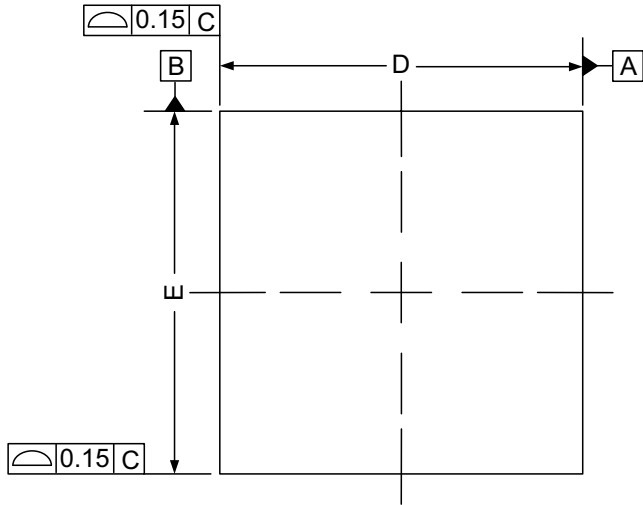

Symbol	Min (mm)	NOM (mm)	Max (mm)
A	0.70	0.75	0.80
A1	0.00	--	0.05
A2	--	0.55	--
A3	--	0.20	--
b	0.20	0.25	0.30
D	1.90	2.00	2.10
D2	1.50	1.60	1.70
E	1.90	2.00	2.10
E2	0.80	0.90	1.00
e	0.50 BSC		
L	0.20	0.30	0.40

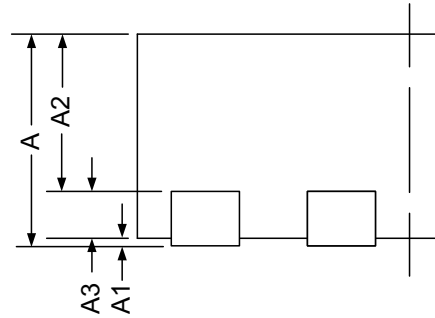
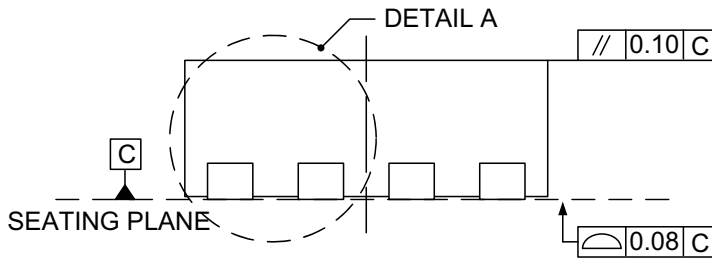

DETAIL A

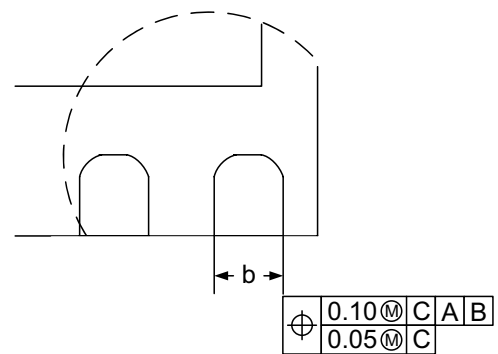
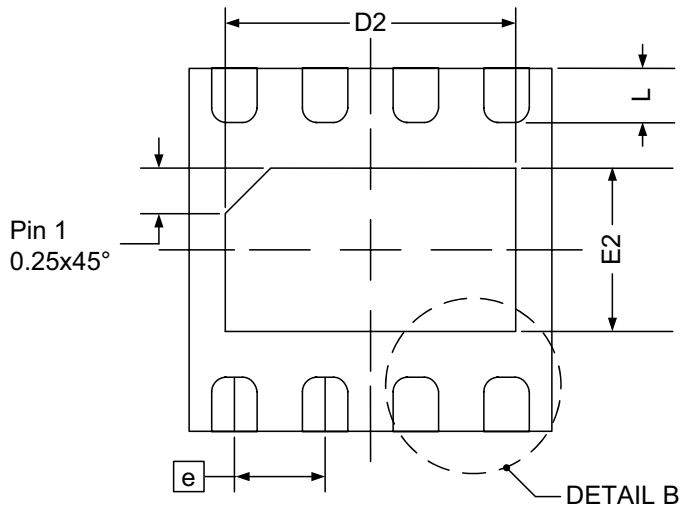

DETAIL B



Tape and Reel Specifications

Package Type	# of Pins	Nominal Package Size	Units per Reel	Trailer A		Leader B		Pocket Tape (mm)		Reel Diameter (mm)
				Pockets	Length (mm)	Pockets	Length (mm)	Width	Pitch	
8TDFN	8	2x2mm	3,000	42	168	42	168	8	4	178

Tape and Reel Drawing

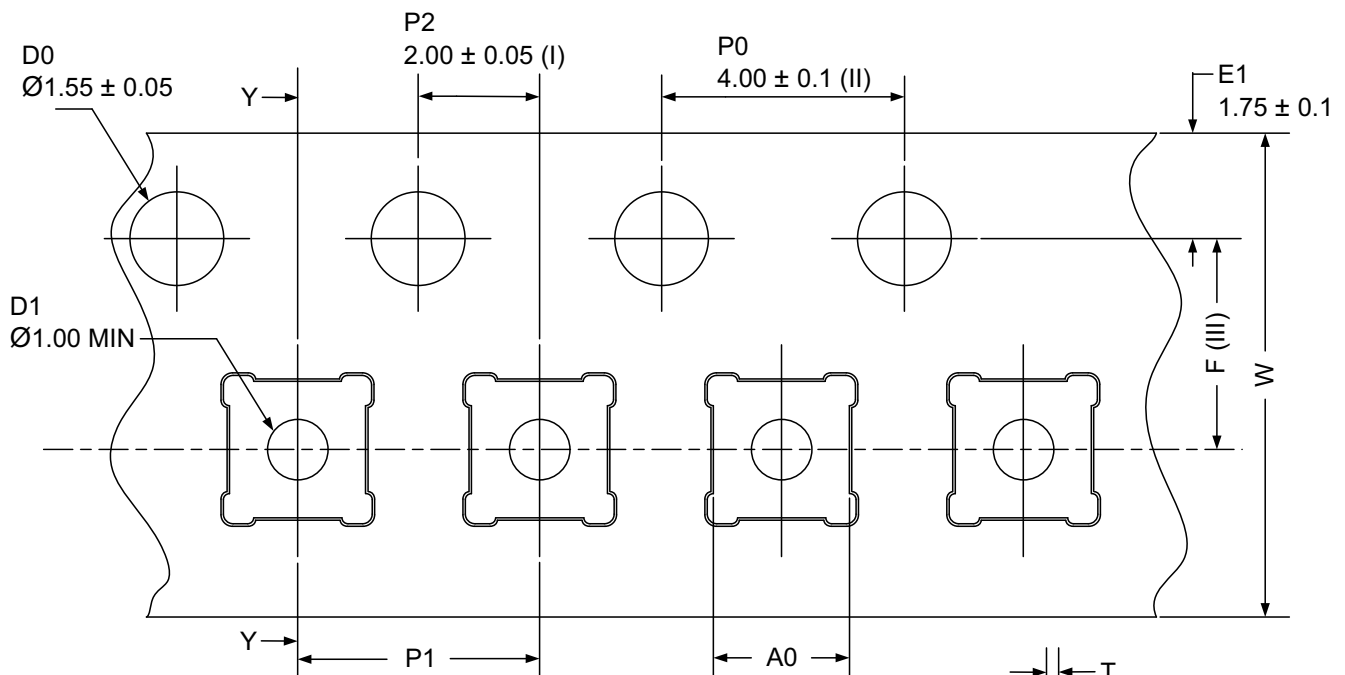

Symbol	(mm)
A0	2.25 ± 0.1
B0	2.25 ± 0.1
K0	1.00 ± 0.1
F	3.50 ± 0.1
P1	4.00 ± 0.1
W	8.00 ± 0.1

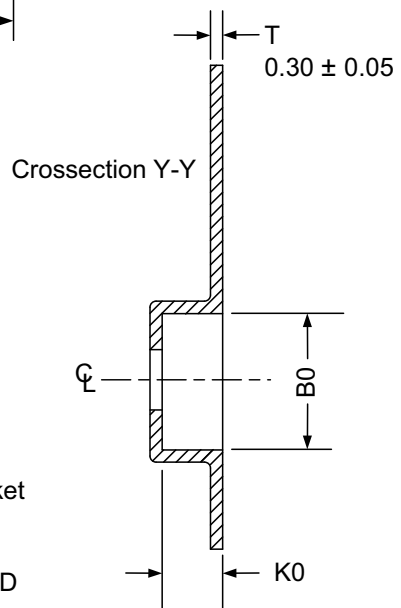

- (I) Measured from centerline of sprocket hole
- (II) Cumulative tolerance of 10 sprocket holes is ± 0.20
- (III) Measured from centerline of sprocket hole to centerline of pocket
- (IV) Other material available

ALL DIMENSIONS IN MILLIMETERS UNLESS OTHERWISE STATED



Silego Website & Support

Silego Technology Website

Silego Technology provides online support via our website at <http://www.silego.com/>. This website is used as a means to make files and information easily available to customers.

For more information regarding Silego Green products, please visit:

<http://greenpak.silego.com/>
<http://greensak.silego.com/>
<http://greenlib.silego.com/>
<http://greenfet.silego.com/>
<http://greenclock.silego.com/>
<http://greenddr3.silego.com/>

Products are also available for purchase directly from Silego at the Silego Online Store at <http://store.silego.com/>.

Silego Technical Support

Datasheets and errata, application notes and example designs, user guides, and hardware support documents and the latest software releases are available at the Silego website or can be requested directly at info@silego.com.

For specific GreenPAK design or applications questions and support please send email requests to GreenPAK@silego.com

Users of Silego products can receive assistance through several channels:

Online Live Support

Silego Technology has live video technical assistance and sales support available at <http://www.silego.com/>. Please ask our live web receptionist to schedule a 1 on 1 training session with one of our application engineers.

Contact Your Local Sales Representative

Customers can contact their local sales representative or field application engineer (FAE) for support. Local sales offices are also available to help customers. More information regarding your local representative is available at the Silego website or send a request to info@silego.com

Contact Silego Directly

Silego can be contacted directly via e-mail at info@silego.com or user submission form, located at the following URL:

<http://support.silego.com/>

Other Information

The latest Silego Technology press releases, listing of seminars and events, listings of world wide Silego Technology offices and representatives are all available at <http://www.silego.com/>

THIS PRODUCT HAS BEEN DESIGNED AND QUALIFIED FOR THE CONSUMER MARKET. APPLICATIONS OR USES AS CRITICAL COMPONENTS IN LIFE SUPPORT DEVICES OR SYSTEMS ARE NOT AUTHORIZED. SILEGO TECHNOLOGY DOES NOT ASSUME ANY LIABILITY ARISING OUT OF SUCH APPLICATIONS OR USES OF ITS PRODUCTS. SILEGO TECHNOLOGY RESERVES THE RIGHT TO IMPROVE PRODUCT DESIGN, FUNCTIONS AND RELIABILITY WITHOUT NOTICE.