

**Harvatek Surface Mount LED Data Sheet  
HT-12H Series**

Official Product	Product: HT-12H Series			Data Sheet No.
Tentative Product	*****			HT-12H Series
Specifications are subject to change without notice. Data and drawings herein are copyrighted.		June 18, 2013	Version of 1.0	Page 1/21

**DISCLAIMER**..... 3

**PRODUCT SPECIFICATIONS** ..... 4

**ATTENTION: ELECTROSTATIC DISCHARGE (ESD) PROTECTION** ..... 5

**LABEL SPECIFICATIONS** ..... 6

**PRODUCT CHARACTERISTICS** ..... 10

**ABSOLUTE MAXIMUM RATINGS** ..... 10

**ELECTRO-OPTICAL CHARACTERISTICS**..... 10

**PACKAGE OUTLINE DIMENSION**..... 11

**RECOMMENDED SOLDERING PATTERN FOR REFLOW SOLDERING**..... 11

**CHARACTERISTIC CURVES FOR NB, NG AND TW** ..... 12

**CHARACTERISTIC CURVES FOR ALL COLORS (RADIATION PATTERN)** ..... 13

**PACKAGING** ..... 14

**TAPE DIMENSION** ..... 14

**REEL DIMENSION** ..... 15

**PACKING** ..... 16

**DRY PACK**..... 17

**REFLOW SOLDERING** ..... 18

**WAVE SOLDERING** ..... 19

**PRECAUTIONS** ..... 19

**REWORKING** ..... 19

**CLEANING** ..... 19

**RELIABILITY** ..... 20

**REVISION HISTORY** ..... 21

Official Product	Product: HT-12H Series		Data Sheet No.
Tentative Product	*****		HT-12H Series
Specifications are subject to change without notice. Data and drawings herein are copyrighted.	June 18, 2013	Version of 1.0	Page 2/21

**DISCLAIMER**

HARVATEK reserves the right to make changes without further notice to any products herein to improve reliability, function or design. HARVATEK does not assume any liability arising out of the application or use of any product or circuit described herein; neither does it convey any license under its patent rights, nor the rights of others.

**LIFE SUPPORT POLICY**

HARVATEK’s products are not authorized for use as critical components in life support devices or systems without the express written approval of the President of HARVATEK or HARVATEK INTERNATIONAL. As used herein:

1. Life support devices or systems are devices or systems which, (a) are intended for surgical implant into the body, or (b) support or sustain life, and (c) whose failure to perform when properly used in accordance with instructions for use provided in the labeling, can be reasonably expected to result in a significant injury of the user.
  
2. A critical component in any component of a life support device or system whose failure to perform can be reasonably expected to cause the failure of the life support device or system, or to affect its safety or effectiveness.

Official Product	Product: HT-12H Series			Data Sheet No.
Tentative Product	*****			HT-12H Series
Specifications are subject to change without notice. Data and drawings herein are copyrighted.	June 18, 2013	Version of 1.0	Page 3/21	

## Product Specifications

Product	Emission Color	Technology	Test Current $I_F$ (mA)	Luminous Intensity $I_V$ (mcd)	Forward Voltage $V_F$ (V)	Orderable Part Number
HT-12HNB5	Blue	InGaN	5	22 typ	2.8 typ	HT-12HNB-YYYY
HT-12HNG5	True Green	InGaN	5	112.5 typ	2.8 typ	HT-12HNG-YYYY
HT-12HTW5	White	InGaN	5	90 typ	2.8 typ	HT-12HTW-YYYY

Official Product	Product: HT-12H Series		Data Sheet No.
Tentative Product	*****		HT-12H Series
Specifications are subject to change without notice. Data and drawings herein are copyrighted.		June 18, 2013	Version of 1.0
			Page 4/21

	Specification	Material	Quantity
Resin	Water clear	Epoxy resin	
Carrier tape	Per EIA 481-1A specs	Conductive black tape	4000pcs per reel
Reel	Per EIA 481-1A specs	Conductive black	
Label	HT standard	Paper	
Packing bag	220x240mm	Aluminum laminated bag/ no-zipper	One reel per bag
Carton	HT standard	Paper	

Others:

Each immediate box consists of 5 reels. The 5 reels may not necessarily have the same lot number or the same bin combinations of  $I_v$ ,  $\lambda_D$  and  $V_f$ . Each reel has a label identifying its specification; the immediate box consists of a product label as well.

**ATTENTION: Electrostatic Discharge (ESD) protection**



The symbol to the left denotes that ESD precaution is needed. ESD protection for GaP and AlGaAs based chips is necessary even though they are relatively safe in the presence of low static-electric discharge. Parts built with AlInGaP, GaN, or/and InGaN based chips are **STATIC SENSITIVE devices**. ESD precaution must be taken during design and assembly.

If manual work or processing is needed, please ensure the device is adequately protected from ESD during the process.

Official Product	Product: HT-12H Series		Data Sheet No.
Tentative Product	*****		HT-12H Series
Specifications are subject to change without notice. Data and drawings herein are copyrighted.	June 18, 2013	Version of 1.0	Page 5/21

**Label Specifications**

<b>HARVATEK</b> TECHNOLOGIES		Date: yyyy/mm/dd 
CUSTOMER P/N: 		
HARVATEK P/N: 	QTY: PCS 	
LOT NO: 	QC	
IV BIN: COLOR BIN: VF:		

■ Harvatek P/N:

**H T - 1 2 H    XXX -    YYYY**

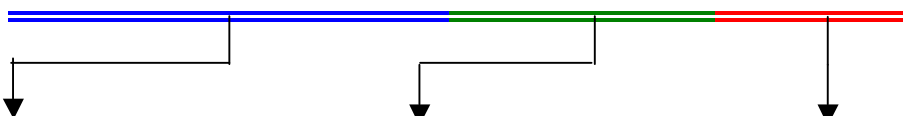

Series Name	Emitting Color	Customer Code
<b>HT-12H</b> HT: Harvatek 1.8 (L) x 1.0 (W) x 0.35 (H) mm	<b>XXX</b> NB5: Blue@5mA NG5: True Green@5mA TW5: White@5mA	<b>YYYY</b> Customer Product Code (TBD)

Official Product	Product: HT-12H Series		Data Sheet No.
Tentative Product	*****		HT-12H Series
Specifications are subject to change without notice. Data and drawings herein are copyrighted.	June 18, 2013	Version of 1.0	Page 6/21

**Lot No.:**

1	2	3	4	5	6	7	8	9	10
<b>E</b>	<b>1</b>	<b>A</b>	<b>1</b>	<b>A</b>	<b>2</b>	<b>2</b>	<b>L</b>	<b>1</b>	<b>2</b>
Code 1 2		Code 3	Code 4	Code 5	Code 6	Code 7	Code 8	Code 9	Code 10
		Mfg. Year	Mfg. Month	Mfg. Date	Consecutive number		Special code		
Internal Tracing Code		2010-A	1:Jan.	1:A	01~ZZ		000~ZZZ		
		2011-B	2:Feb.	2:B					
		2012-C	....	3:C					
		2013-D	A:Oct.	26:Z					
		.	B:Nov.	27:7					
		.	C:Dec.	28:8					
				29:9					
		30:3							
		31:4							

Official Product	Product: HT-12H Series		Data Sheet No.
Tentative Product	*****		HT-12H Series
Specifications are subject to change without notice. Data and drawings herein are copyrighted.	June 18, 2013	Version of 1.0	Page 7/21

■ **Luminous Intensity (I<sub>v</sub>) Bin:**

Bin	Luminous Intensity Range (mcd)		Bin	Luminous Intensity Range (mcd)	
	Minimum	Maximum		Minimum	Maximum
L1	11.2	14.2	L2	14.2	18.0
M1	18.0	22.5	M2	22.5	28.5
N1	28.5	36.0	N2	36.0	45.0
P1	45.0	57.0	P2	57.0	71.5
Q1	71.5	90.0	Q2	90.0	112.5
R1	112.5	142.0	R2	142.0	180.0

@5mA / Ta=25<sup>o</sup> C, Tolerance: ± 10%

■ **Wavelength (λ<sub>D</sub>) Bin:**

Bin	Wavelength Range (nm)			
	True Green (NG)		Blue (NB)	
	Min	Max	Min	Max
A	515.0	520.0	460.0	464.0
B	520.0	525.0	464.0	468.0
C	525.0	530.0	468.0	472.0
D	530.0	535.0	472.0	476.0
E	535.0	540.0	476.0	480.0
F			480.0	485.0

@5mA / Ta=25<sup>o</sup> C, Tolerance: ± 0.5nm

■ **Forward Voltage (V<sub>F</sub>) Bin:**

Color	Bin Code	Spec. Range
Blue (NB) Green (NG) White (TW)	G8	2.7-2.9 V
	H7	2.9-3.1 V
	H8	3.1-3.3 V
	J7	3.3-3.5 V
	J8	3.5-3.7 V
	K7	3.7-3.9 V

@5mA / Ta=25<sup>o</sup> C, Tolerance: ± 0.05 V

Official Product	Product: HT-12H Series	Data Sheet No.
Tentative Product	*****	HT-12H Series
Specifications are subject to change without notice. Data and drawings herein are copyrighted.	June 18, 2013	Version of 1.0
		Page 8/21



**Chromaticity Bin (for TW only):**

		Rank C1			
x		0.2500	0.2700	0.2700	0.2500
y		0.2500	0.2775	0.2325	0.2050

		Rank C2			
x		0.2700	0.2900	0.2900	0.2700
y		0.2775	0.3050	0.2600	0.2325

		Rank D1			
x		0.2900	0.3100	0.3100	0.2900
y		0.3050	0.3325	0.2875	0.2600

		Rank D2			
x		0.3100	0.3300	0.3300	0.3100
y		0.3325	0.3600	0.3150	0.2875

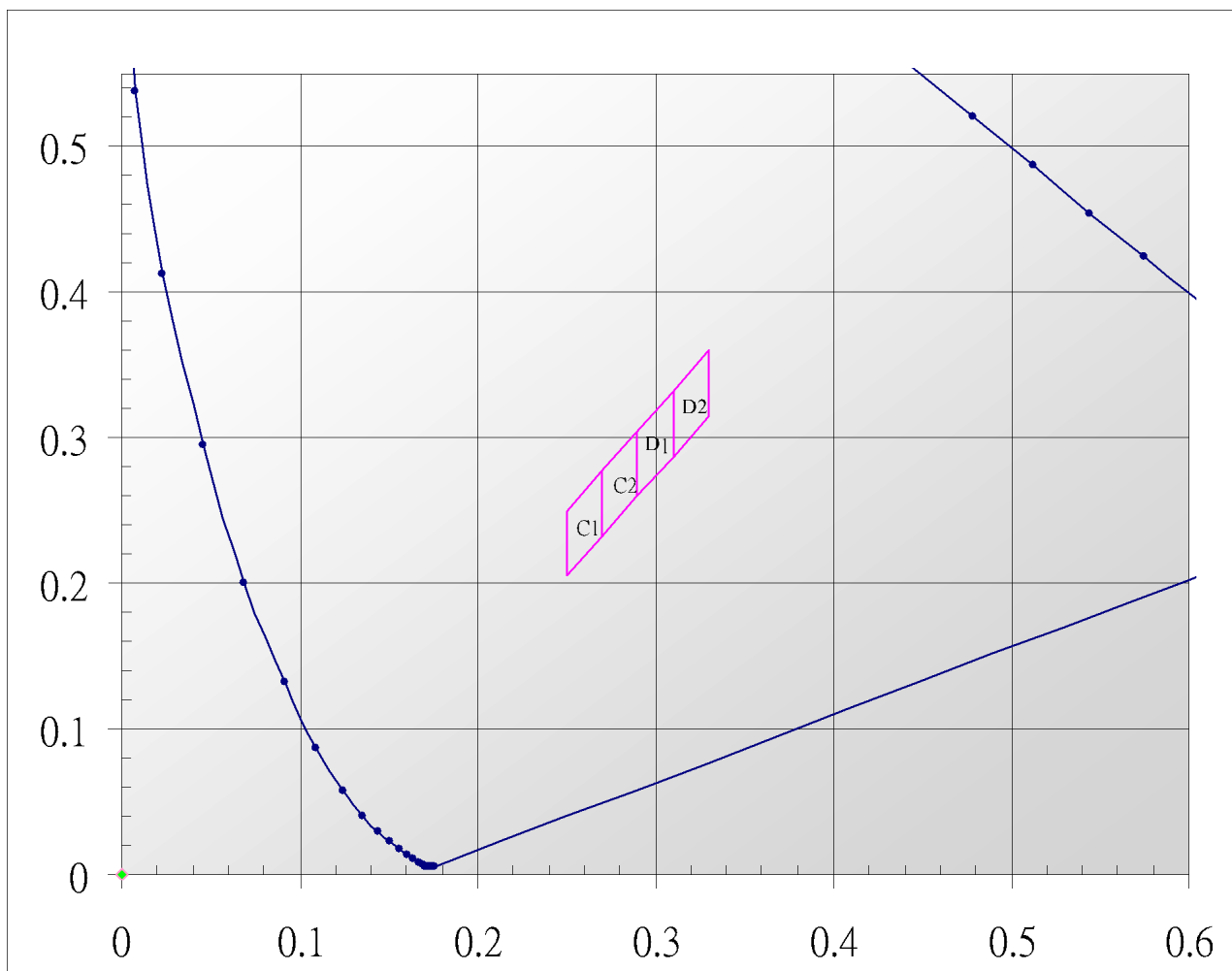

@5mA / Ta=25°C, Tolerance: ± 0.01

Official Product	Product: HT-12H Series		Data Sheet No.
Tentative Product	*****		HT-12H Series
Specifications are subject to change without notice. Data and drawings herein are copyrighted.	June 18, 2013	Version of 1.0	Page 9/21

**Product Characteristics**
**Absolute Maximum Ratings**

Product	Emission Color	P <sub>d</sub> (mW)	I <sub>F</sub> (mA)	I <sub>FP</sub> * (mA)	V <sub>R</sub> (V)	T <sub>OP</sub> (°C)	T <sub>ST</sub> (°C)
HT-121NB5	Blue	78	20	80	5	-30°C~+80°C	-40°C~+85°C
HT-121NG5	True Green						
HT-121TW5	White						

\* Condition for I<sub>FP</sub> is pulse of 1/10 duty and 0.1msec width

**Electro-Optical Characteristics**

(T<sub>a</sub> 25 °C)

Product	Emission Color	I <sub>F</sub> (mA)	V <sub>F</sub> (V)		λ(nm)			I <sub>V</sub> (mcd)
			typ	max	λ <sub>D</sub>	λ <sub>P</sub>	Δλ	typ
HT-121NB5	Blue	5	2.8	3.15	470	468	40	22
HT-121NG5	True Green	5	2.8	3.15	527	520	40	112.5
HT-121TW5	White	5	2.8	3.15	X=0.29 Y=0.31	-	-	90

\* Per NIST standards

\*\*Remarks: This product should be operated in forward bias. If a reverse voltage is continuously applied to the product, such operation can cause migration resulting in LED damage.

Official Product	Product: HT-12H Series	Data Sheet No.
Tentative Product	*****	HT-12H Series
Specifications are subject to change without notice. Data and drawings herein are copyrighted.	June 18, 2013	Version of 1.0
		Page 10/21

**Package Outline Dimension  
Recommended Soldering Pattern for Reflow Soldering**

Unit: mm Tolerance: +/-0.1

Outline Dimension	Solder Pattern
<p>Soldering terminals may shift in the x, y direction.</p>	<p>Unit: mm</p>

Official Product	Product: HT-12H Series		Data Sheet No.
Tentative Product	*****		HT-12H Series
Specifications are subject to change without notice. Data and drawings herein are copyrighted.	June 18, 2013	Version of 1.0	Page 11/21

**Characteristic Curves for NB, NG and TW**

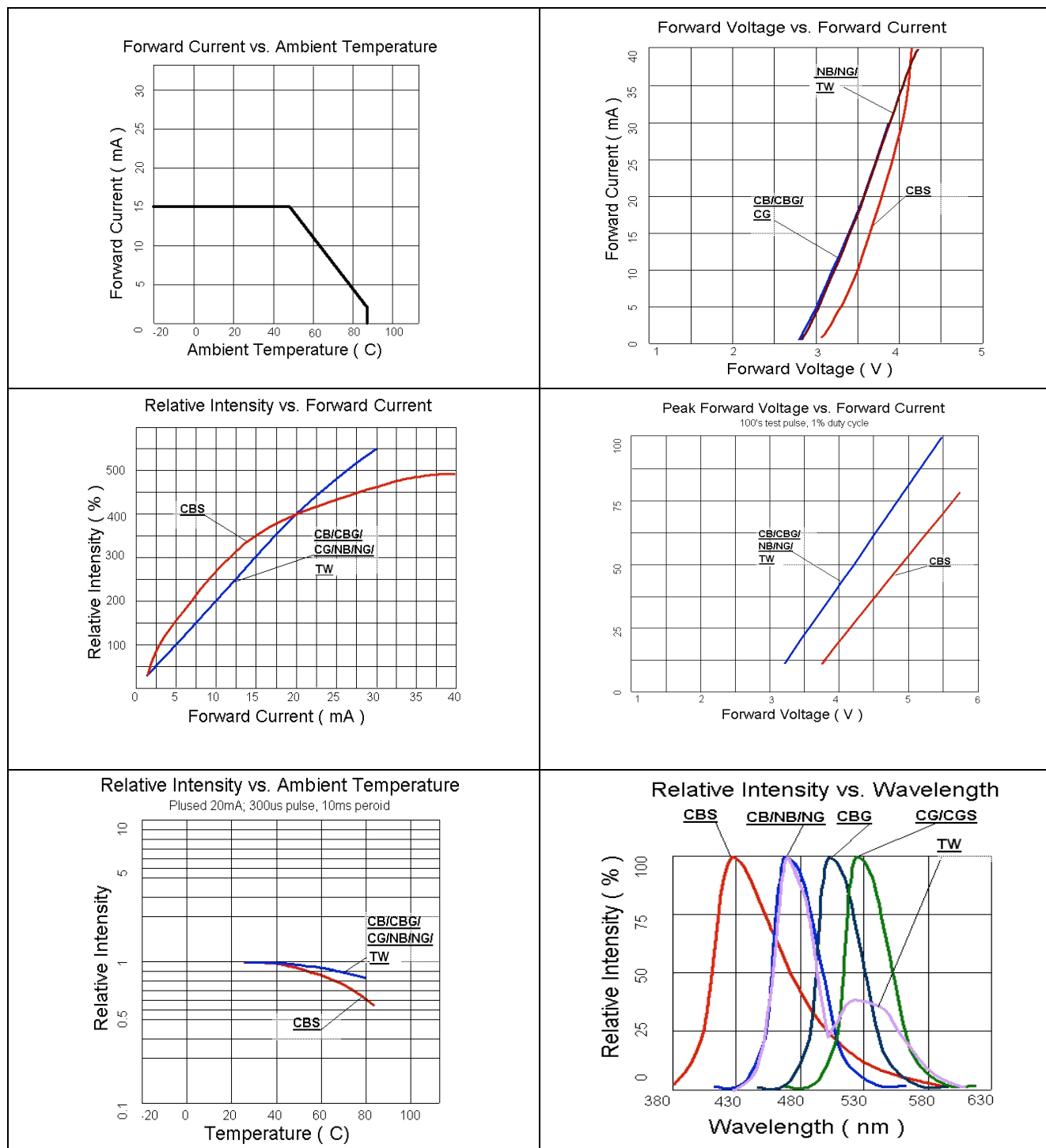

Official Product	Product: HT-12H Series	Data Sheet No.
Tentative Product	*****	HT-12H Series
Specifications are subject to change without notice. Data and drawings herein are copyrighted.	June 18, 2013	Version of 1.0
		Page 12/21

**Characteristic Curves for All Colors (Radiation Pattern)**

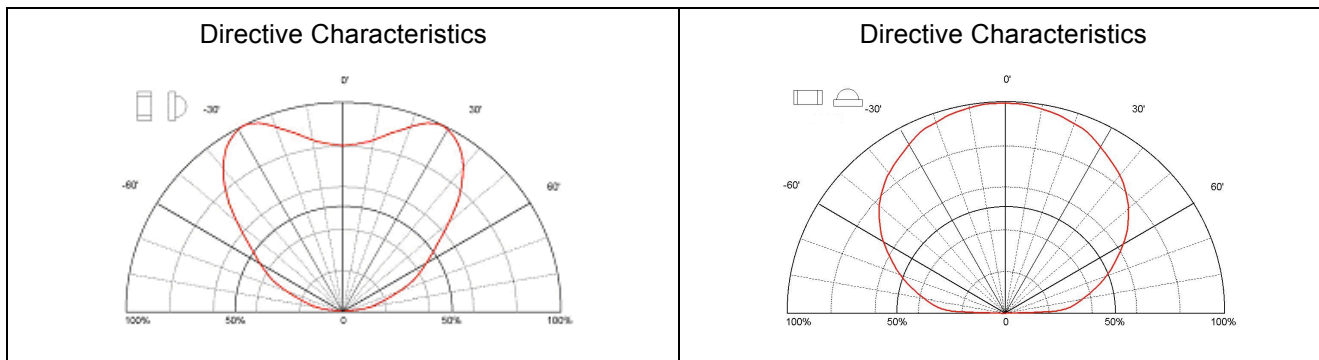

Official Product	Product: HT-12H Series	Data Sheet No.	
Tentative Product	*****	HT-12H Series	
Specifications are subject to change without notice. Data and drawings herein are copyrighted.	June 18, 2013	Version of 1.0	Page 13/21

**Packaging**

**Tape Dimension**

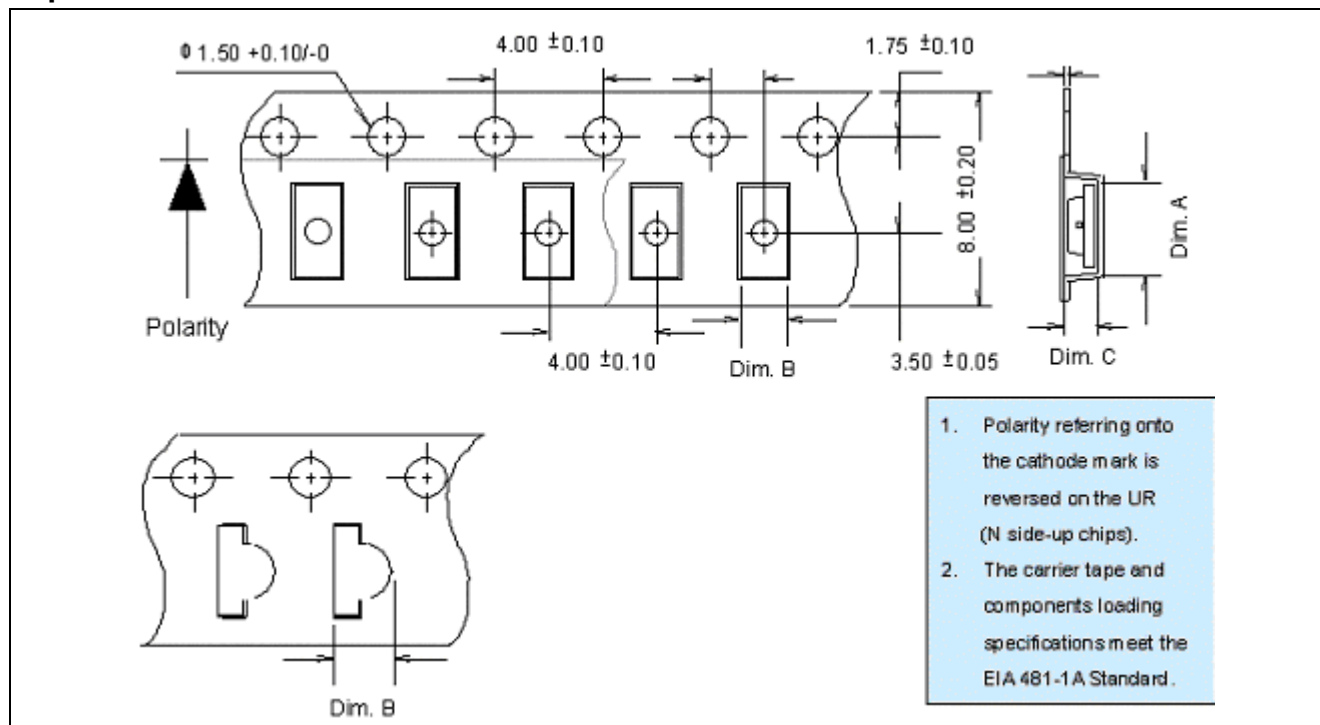

Part No.	Dim. A	Dim. B	Dim. C	Q'ty/Reel
HT-12H	1.90±0.10	1.15±0.10	0.80±0.10	4K

**Unit: mm**

Official Product	Product: HT-12H Series		Data Sheet No.
Tentative Product	*****		HT-12H Series
Specifications are subject to change without notice. Data and drawings herein are copyrighted.		June 18, 2013	Version of 1.0
			Page 14/21

**Reel Dimension**

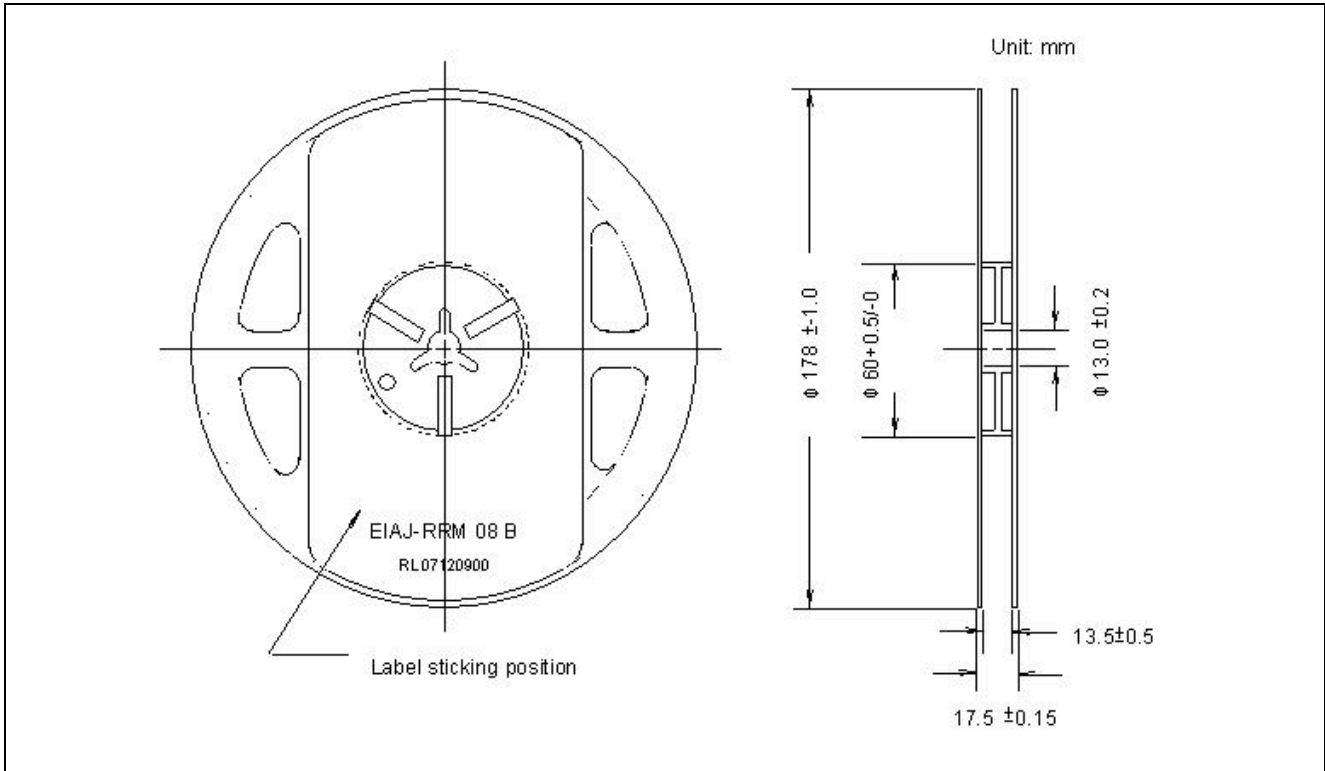

Official Product	Product: HT-12H Series	Data Sheet No.
Tentative Product	*****	HT-12H Series
Specifications are subject to change without notice. Data and drawings herein are copyrighted.	June 18, 2013	Version of 1.0
		Page 15/21

**Packing**

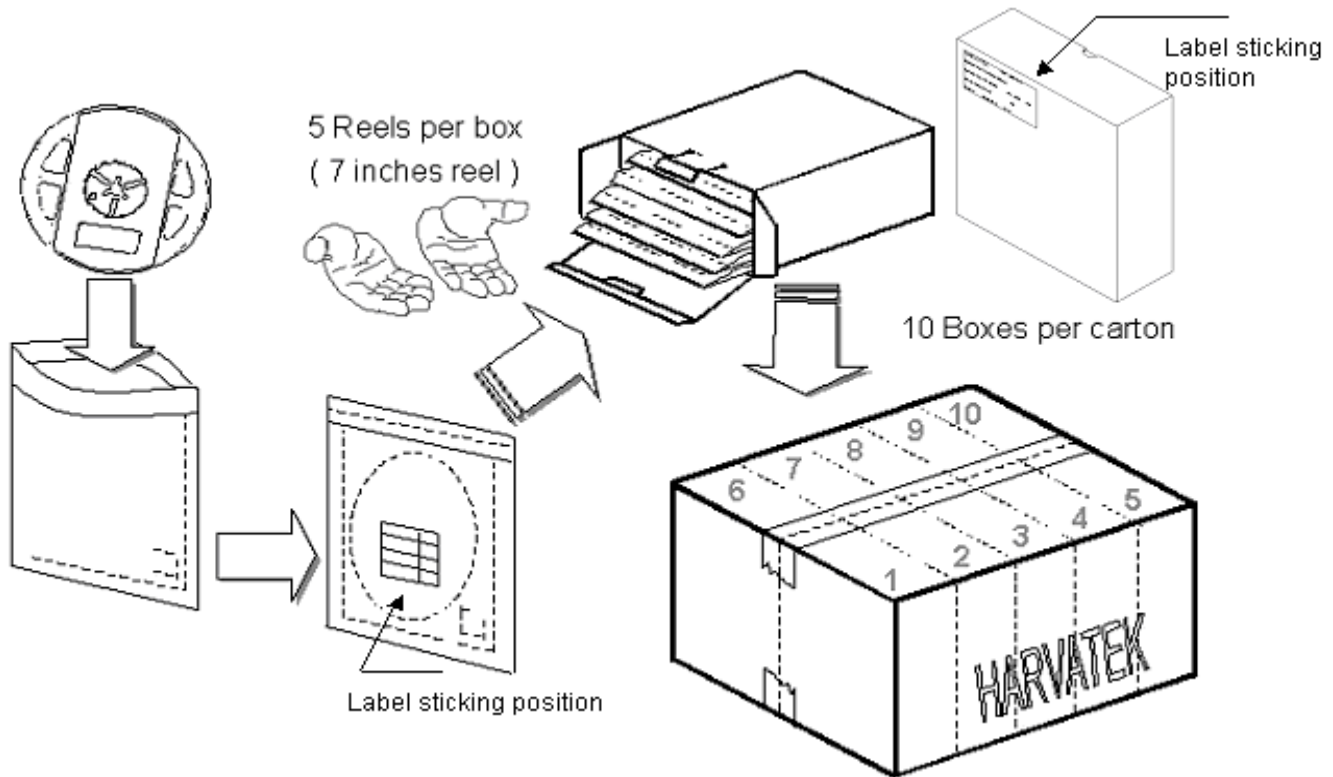

5 boxes per carton is available depending on shipment quantity.

	Specification	Material	Quantity
Carrier tape	Per EIA 481-1A specs	Conductive black tape	4000pcs per reel
Reel	Per EIA 481-1A specs	Conductive black	
Label	HT standard	Paper	
Packing bag	220x240mm	Aluminum laminated bag/ no-zipper	One reel per bag
Carton	HT standard	Paper	Non-specified

Others:

Each immediate box consists of 5 reels. The 5 reels may not necessarily have the same lot number or the same bin combinations of Iv,  $\lambda_D$  and Vf. Each reel has a label identifying its specification; the immediate box consists of a product label as well.

Official Product	Product: HT-12H Series	Data Sheet No.
Tentative Product	*****	HT-12H Series
Specifications are subject to change without notice. Data and drawings herein are copyrighted.	June 18, 2013	Version of 1.0
		Page 16/21



**Dry Pack**

All SMD optical devices are **MOISTURE SENSITIVE**. Avoid exposure to moisture at all times during transportation or storage. Every reel is packaged in a moisture protected anti-static bag. Each bag is properly sealed prior to shipment.

Upon request, a humidity indicator will be included in the moisture protected anti-static bag prior to shipment.

The packaging sequence is as follows:

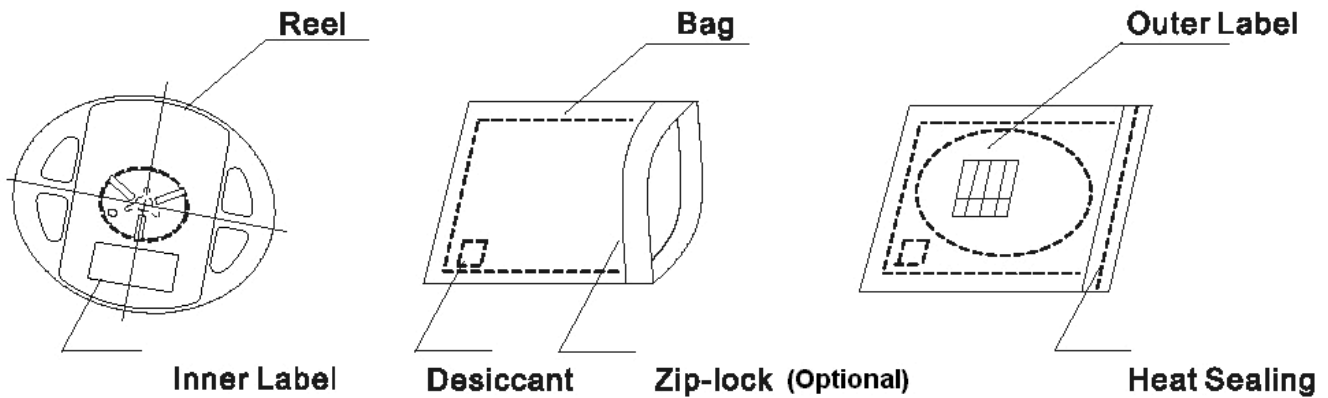

Official Product	Product: HT-12H Series		Data Sheet No.
Tentative Product	*****		HT-12H Series
Specifications are subject to change without notice. Data and drawings herein are copyrighted.	June 18, 2013	Version of 1.0	Page 17/21

**Reflow Soldering**

- Recommended tin glue specifications: melting temperature in the range of 178~192 °C
- The recommended reflow soldering profile is as follows (temperatures indicated are as measured on the surface of the LED resin):

Lead Solder Profile

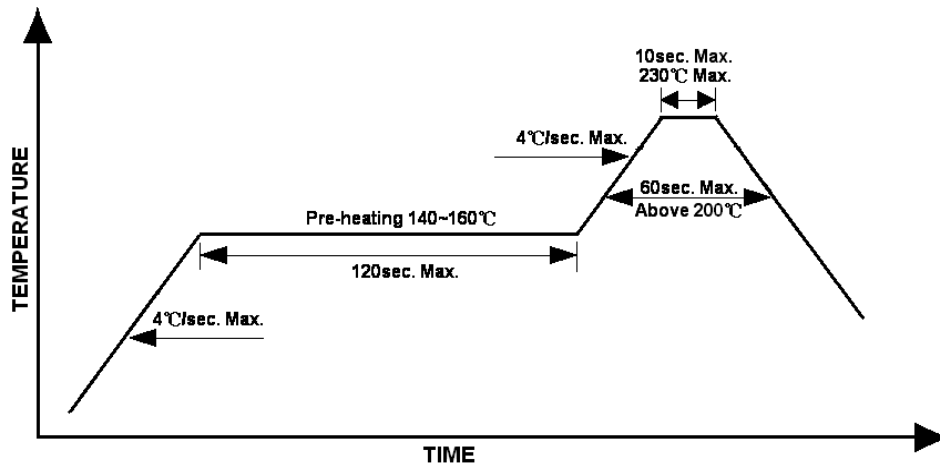

Lead-free Solder Profile

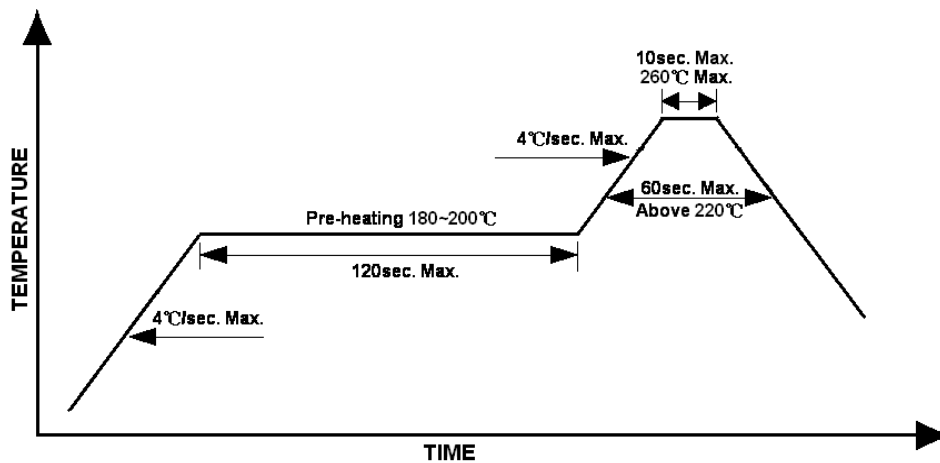

Official Product	Product: HT-12H Series	Data Sheet No.	
Tentative Product	*****	HT-12H Series	
Specifications are subject to change without notice. Data and drawings herein are copyrighted.	June 18, 2013	Version of 1.0	Page 18/21

### Wave Soldering

- Maximum soldering temperature is 260°C for 5 seconds.

### Precautions

1. Avoid exposure to moisture at all times during transportation or storage.
2. Anti-Static precaution must be taken when handling GaN, InGaN, and AlInGaP products.
3. It is suggested to connect the unit with a current limiting resistor of the proper size. Avoid applying a reverse voltage.
4. Avoid operation beyond the limits as specified by the absolute maximum ratings.
5. Avoid direct contact with the surface through which the LED emits light.
6. If possible, assemble the unit in a clean room or dust-free environment.

### Reworking

- Rework should be completed within 5 seconds under 260 °C.
- The iron tip must not come in contact with the copper foil.
- Twin-head type is preferred.

### Cleaning

Following are cleaning procedures after soldering:

- An alcohol-based solvent such as isopropyl alcohol (IPA) is recommended.
- Temperature x Time should be 50°C x 30sec. or <30°C x 3min
- Ultra sonic cleaning: < 15W/ bath; bath volume ≤ 1liter
- Curing: 100 °C max, <3min

### Cautions of Pick and Place

- Avoid stress on the resin at elevated temperature.
- Avoid rubbing or scraping the resin by any object.
- Electro-static may cause damage to the component. Please ensure that the equipment is properly grounded. Use of an ionizer fan is recommended.

Official Product	Product: HT-12H Series		Data Sheet No.
Tentative Product	*****		HT-12H Series
Specifications are subject to change without notice. Data and drawings herein are copyrighted.	June 18, 2013	Version of 1.0	Page 19/21

### Reliability

Item	Frequency/ lots/ samples/ failures	Standards Reference	Conditions
Precondition	For all reliability monitoring tests according to JEDEC Level 2	J-STD-020	1.) Baking at 85°C for 24hrs 2.) Moisture storage at 85°C/ 60% R.H. for 168hrs
Solderability	1Q/ 1/ 22/ 0	JESD22-B102-B And CNS-5068	Accelerated aging 155°C/ 24hrs Tinning speed: 2.5+0.5cm/s Tinning: A: 215°C/ 3+1s or B: 260°C/ 10+1s
Resistance to soldering heat		CNS-5067	Dipping soldering terminal only Soldering bath temperature A: 260+/-5°C; 10+/-1s B: 350+/-10°C; 3+/-0.5s
Operating life test	1Q/ 1/ 40/ 0	CNS-11829	1.) Precondition: 85°C baking for 24hrs 85°C/ 60%R.H. for 168hrs 2.) Tamb25°C; IF=20mA; duration 1000hrs
High humidity, high temperature bias	1Q/ 1/ 45/ 0	JESD-A101-B	Tamb: 85°C Humidity: 85% R.H., IF=5mA Duration: 1000hrs
High temperature bias	1Q/ 1/ 20	HT specs.	Tamb: 55°C IF=20mA Duration: 1000hrs
Pulse life test	1Q/ 1/ 40/ 0		Tamb25°C, If=20mA., Ip=100mA, Duty cycle=0.125 (tp=125 μs, T=1sec) Duration 500hrs)
Temperature cycle	1Q/ 1/ 76/ 0	JESD-A104-A IEC 68-2-14, Nb	A cycle: -40 degree C 15min; +85 degree C 15min Thermal steady within 5 min.. 300 cycles 2 chamber/ Air-to-air type
High humidity storage test	1Q/ 1/ 40/ 0	CNS-6117	60+3°C 90+5/-10% R.H. for 500hrs
High temperature storage test	1Q/ 1/ 40/ 0	CNS-554	100+10°C for 500hrs
Low temperature storage test	1Q/ 1/ 40/ 0	CNS-6118	-40+5°C for 500hrs

Official Product	Product: HT-12H Series		Data Sheet No.
Tentative Product	*****		HT-12H Series
Specifications are subject to change without notice. Data and drawings herein are copyrighted.	June 18, 2013	Version of 1.0	Page 20/21

**Revision History**

Changes since last revision	Page	Version No.	Revision Date
Initial Release		1.0	06-18-2013

Official Product	Product: HT-12H Series		Data Sheet No.
Tentative Product	*****		HT-12H Series
Specifications are subject to change without notice. Data and drawings herein are copyrighted.	June 18, 2013	Version of 1.0	Page 21/21