

AZ DISPLAYS

SPECIFICATIONS FOR LIQUID CRYSTAL DISPLAY

| CUSTOMER APPROVAL | | | |
|---|--|-----------------|--|
| ※ PART NO. : <u>ATM0800L3A-T (AZ DISPLAYS) VER1.0</u> | | | |
| APPROVAL | | COMPANY CHOP | |
| CUSTOMER COMMENTS | | | |

| AZ DISPLAYS ENGINEERING APPROVAL | | |
|----------------------------------|------------|-------------|
| DESIGNED BY | CHECKED BY | APPROVED BY |
| YGB | | |

REVISION RECORD

| REVISION | REVISION DATE | PAGE | CONTENTS |
|---------------|-------------------|------|---------------------|
| VER1.0 | 22/05-2012 | | FIRST ISSUED |

※ **CONTENTS**

- 1.0 MECHANICAL DIAGRAM
- 2.0 GENERAL SPECIFICATION
- 3.0 ABSOLUTE MAXIMUM RATINGS
- 4.0 ELECTRICAL CHARACTERISTICS
- 5.0 OPTICAL CHARACTERISTICS
- 6.0 BLOCK DIAGRAM
- 7.0 PIN ASSIGNMENT
- 8.0 TIMING CHARACTERISTICS
- 9.0 RELIABILITY TEST
- 10.0 PRECAUTION FOR USING LCM

ATM0800L3A-T(AZ DISPLAYS) TFT MODULE V1.0

1.0 MECHANICAL DIAGRAM

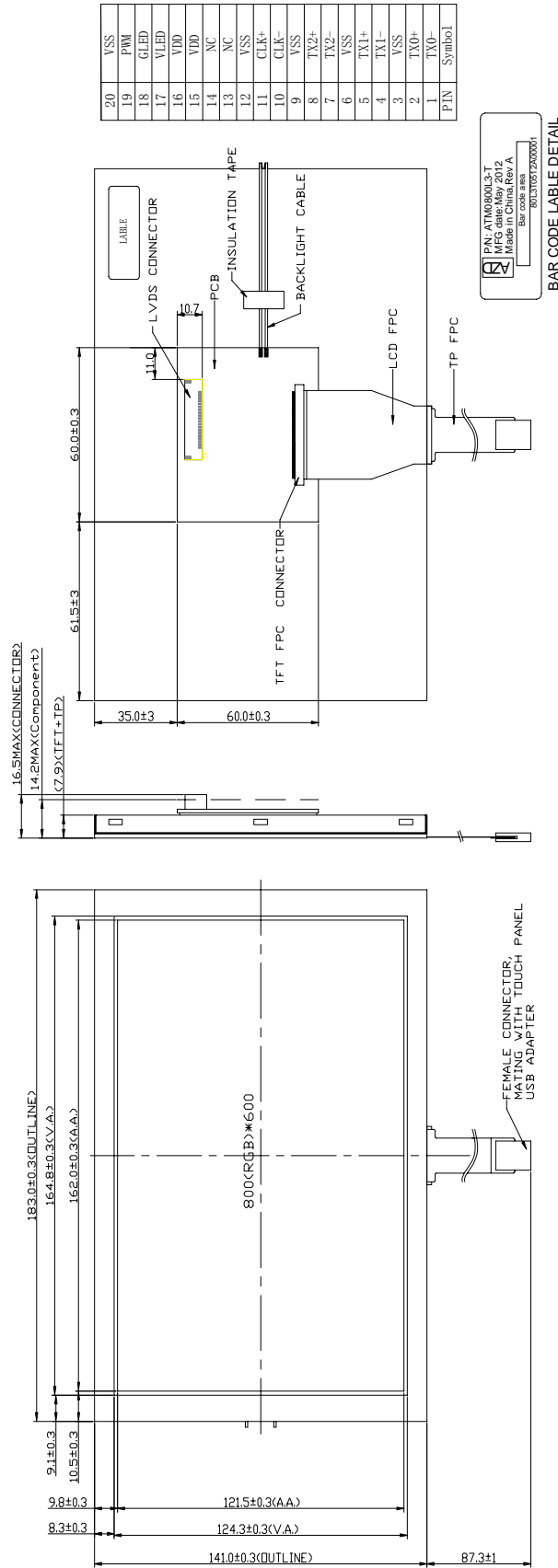

2.0 MECHANICAL SPECS

| | |
|---------------------------|--|
| 1. Display Format | 800RGB*600 DOTS |
| 2. Power Supply | LCD 3.3V/ BL 12V |
| 3. Overall Module Size | 183.0mm(L) x 141.0mm(W) x MAX13.1mm(T) |
| 4. Viewing Area(W*H) | 164.8mm(L)x124.3mm(W) |
| 5. Color Configuration | RGB stripe |
| 6. Color Depth | 262K colors |
| 7. NTSC Ratio | 50% |
| 8. Dot Pitch (W*H) | 0.2025mm(W) x 0.2025mm(H) |
| 9. Viewing Direction | 6 O'clock |
| 10. Display mode | Normally white |
| 11. Backlight Options | LED-SIDE(White) |
| 12. Operating temperature | -20°C ~ 70°C |
| 13. Storage temperature | -30°C ~ 80°C |
| 14. Weight | T.B.D. |
| 15. ROHS | ROHS compliant |

3.0 ABSOLUTE MAXIMUM RATINGS

| Item | Symbol | Min | Typ | Max | Unit |
|--------------------------|----------|---------|-----|---------|------|
| Operating temperature | Top | -20 | - | 70 | °C |
| Storage temperature | Tst | -30 | - | 80 | °C |
| Input voltage | Vin | Vss-0.3 | - | Vdd+0.3 | V |
| Supply voltage for logic | Vdd- Vss | -0.3 | - | 3.6 | V |

4.0 ELECTRICAL CHARACTERISTICS

4.1 Electrical Characteristics Of LCM

| Item | Symbol | Condition | Min | Typ | Max | Unit |
|----------------------|------------------|--------------------------|--------|-----|--------|------|
| Power Supply Voltage | VDD | Ta = 25°C | 3.0 | 3.3 | 3.6 | V |
| BL power consumption | P _{BL} | V _{BL_IN} = 12V | -- | 140 | -- | mA |
| Power Consumption | P _{TFT} | Vdd = 3.3V | - | 230 | -- | mA |
| Input voltage (high) | Vih | H level | 0.8Vdd | - | Vdd | V |
| Input voltage (low) | Vil | L level | Vss | - | 0.2Vdd | V |

4.2 The Characteristics Of Backlight

| Item | Symbol | Condition | Min | Typ | Max | Unit |
|-------------------|-----------|---------------|-------|------|-----|------|
| Power consumption | P_{LED} | $I_L = 180mA$ | -- | 1.78 | -- | W |
| LED life time | -- | -- | 20000 | -- | -- | H |

Note 1: LED backlight is LED lightbar type;

Note 2: Definition of "LED Lifetime": brightness is decreased to 50% of the initial value. LED Lifetime is restricted under normal condition, ambient temperature = 25°C and LED lightbar current = 180mA

Note 3. The value is only for reference

Note 4. If it operates with LED lightbar current more than 180mA, it may decrease LED lifetime.

5.0 OPTICAL CHARACTERISTICS

| Item | Symbol | Condition | Min | Typ | Max | Unit | Remarks | Note |
|---------------------|----------|--------------|-----|-----|-----|-------|---------------------------|------|
| Reponse time | Tr | Ta = 25°C | --- | 10 | 20 | ms | --- | 1 |
| | Tf | | --- | 15 | 30 | ms | --- | 1 |
| Luminance | L | Il = 180mA | 160 | 200 | -- | Cd/m2 | --- | -- |
| Contrast | | Ta = 25°C | 400 | 500 | --- | --- | --- | 2 |
| Viewing angle range | θ | Cr \geq 10 | --- | 50 | --- | deg | $\varnothing = 90^\circ$ | 3 |
| | | | --- | 70 | --- | deg | $\varnothing = 270^\circ$ | 3 |
| | | | --- | 70 | --- | deg | $\varnothing = 0^\circ$ | 3 |
| | | | --- | 70 | --- | deg | $\varnothing = 180^\circ$ | 3 |

Note1: Definition of response time.

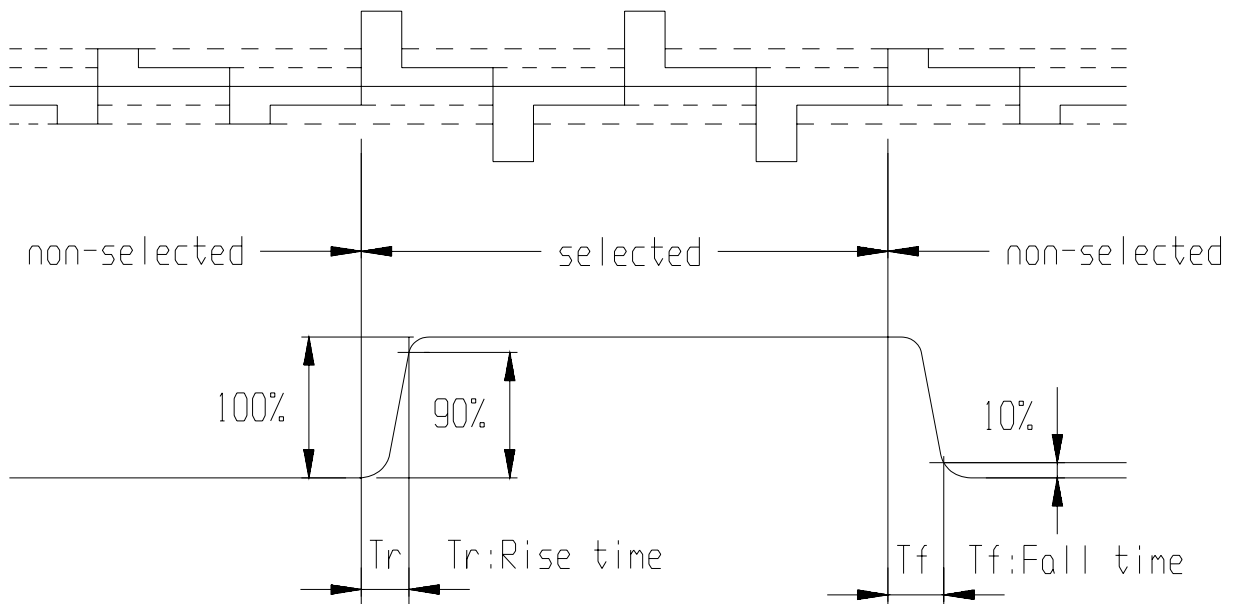

Note2: Definition of contrast ratio 'Cr' .

Note3: Definition of viewing angle range ' θ '.

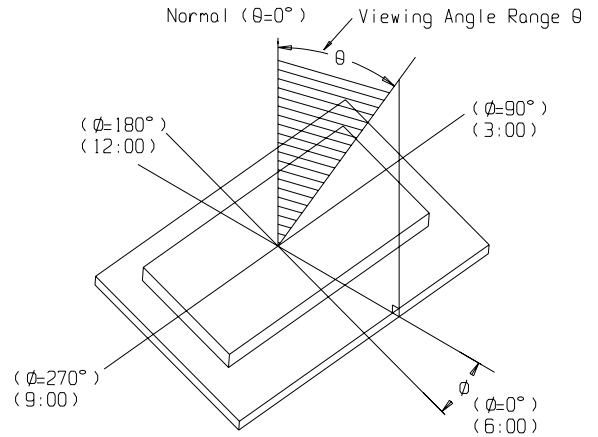
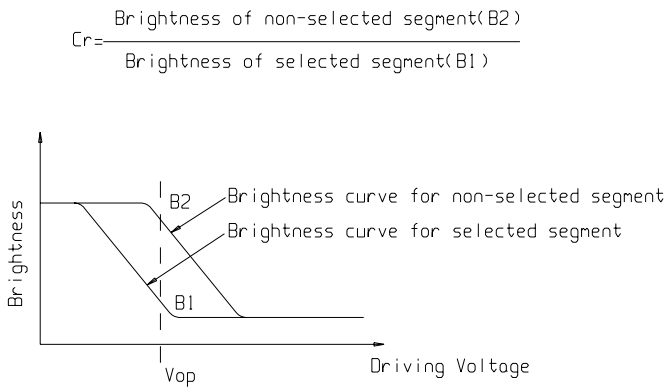

6.0 BLOCK DIAGRAM

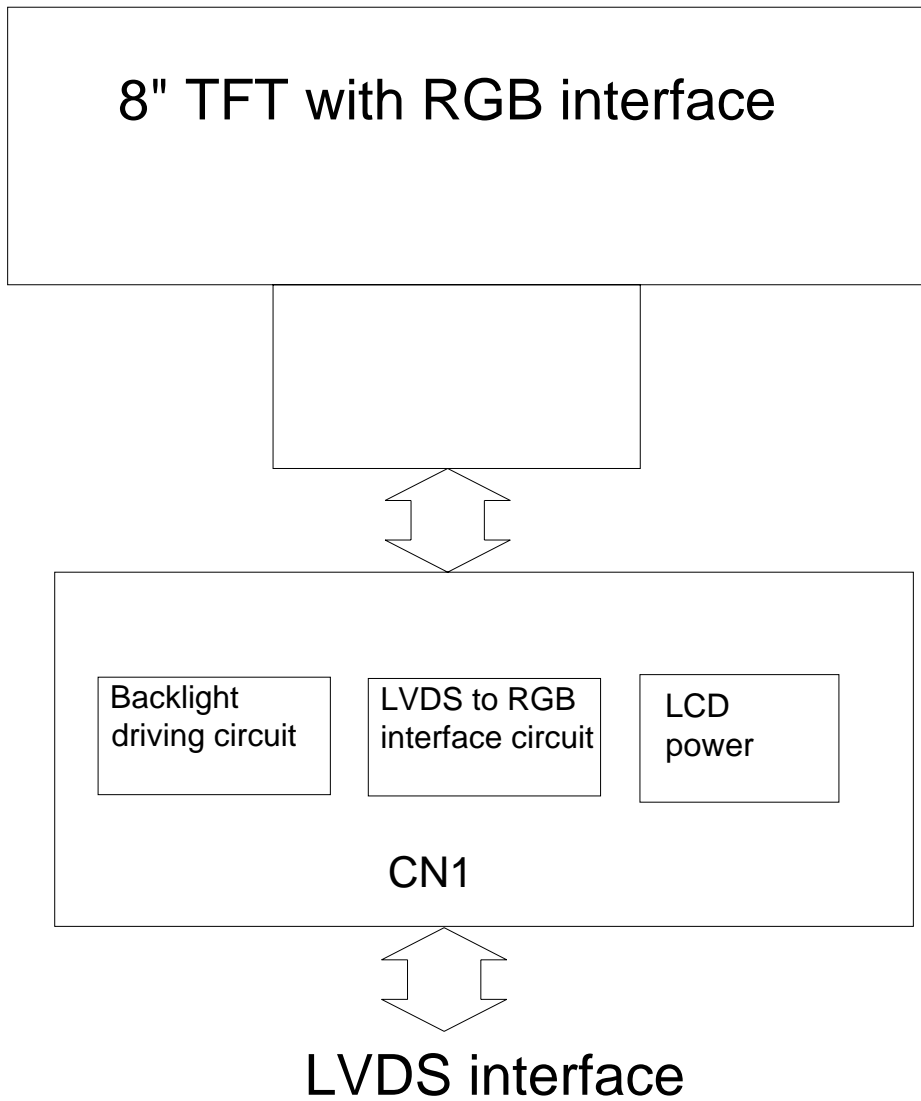

ATM0800L3A-T(AZ DISPLAYS) TFT MODULE V1.0

7.0 PIN ASSIGNMENT

Connector on board: H1009H-20 Pitch=1.0mm

| Pin No. | Symbol | Function |
|---------|--------|--|
| 1 | TX0- | Negative LVDS differential data input(R0-R5,G0)*3 |
| 2 | TX0+ | Positive LVDS differential data input(R0-R5,G0)*3 |
| 3 | VSS*1 | GROUND |
| 4 | TX1- | Negative LVDS differential data input(G1-G5,B0-B1)*3 |
| 5 | TX1+ | Positive LVDS differential data input(G1-G5,B0-B1)*3 |
| 6 | VSS*1 | GROUND |
| 7 | TX2- | Negative LVDS differential data input(B2-R5,HS,VS,DE)*3 |
| 8 | TX2+ | Positive LVDS differential data input(B2-R5,HS,VS,DE)*3 |
| 9 | VSS*1 | GROUND |
| 10 | CLK- | Clock Signal(-) |
| 11 | CLK+ | Clock signal(+) |
| 12 | VSS*1 | GROUND |
| 13 | NC*2 | Non Connection(open) |
| 14 | NC*2 | Non Connection(open) |
| 15 | VDD | +3.3V POWER SUPPLY FOR LOGIC AND LCM POWER |
| 16 | VDD | +3.3V POWER SUPPLY FOR LOGIC AND LCM POWER |
| 17 | VLED | +12V POWER SUPPLY FOR BACKLIGHT |
| 18 | GLED | POWER GROUND FOR BACKLIGHT |
| 19 | PWM | BACKLIGHT ON/OFF/DIMMING CONTROL(PWM:100~1000HZ, 0~100%) |
| 20 | VSS*1 | GROUND |

NOTE 1) PLEASE CONNECT GND PIN TO GROUND. DON'T USE IT AS NO-CONNECT NOR CONNECTION WITH HIGH IMPEDANCE.

NOTE 2) PLEASE CONNECT NC PIN TO NOTHING. DON'T CONNECT IT TO GROUND NOR TO OTHER SIGNAL INPUT.

NOTE 3) REFER TO NEXT PAGE.

ATM0800L3A-T(AZ DISPLAYS) TFT MODULE V1.0

RECOMMENDED TRANSMITTER(DS90C365)TO ATM0800D3L-T INTERFACE ASSIGNMENT

| DS90C365 | | | | LT084AC27500 Interface (CN1) | | |
|--------------------|----------|---|---------------------------------|------------------------------------|----------------|------------------|
| Input Terminal No. | | Input Signal (Graphics controller output signal) | | Output Signal Symbol | | |
| Symbol | Terminal | Symbol | Function | | Terminal | Symbol |
| TxIN0 | 44 | R0 | Red Pixels Display Data (LSB) | TxOUT0- TxOUT0+ | No.5 No.6 | RxIN0- RxIN0+ |
| TxIN1 | 45 | R1 | Red Pixels Display Data | | | |
| TxIN2 | 47 | R2 | Red Pixels Display Data | | | |
| TxIN3 | 48 | R3 | Red Pixels Display Data | | | |
| TxIN4 | 1 | R4 | Red Pixels Display Data | | | |
| TxIN5 | 3 | R5 | Red Pixels Display Data (MSB) | TxOUT1- TxOUT1+ | No.8 No.9 | RxIN1- RxIN1+ |
| TxIN6 | 4 | G0 | Green Pixels Display Data (LSB) | | | |
| TxIN7 | 6 | G1 | Green Pixels Display Data | | | |
| TxIN8 | 7 | G2 | Green Pixels Display Data | | | |
| TxIN9 | 9 | G3 | Green Pixels Display Data | | | |
| TxIN10 | 10 | G4 | Green Pixels Display Data | TxOUT2- TxOUT2+ | No.11 No.12 | RxIN2- RxIN2+ |
| TxIN11 | 12 | G5 | Green Pixels Display Data (MSB) | | | |
| TxIN12 | 13 | B0 | Blue Pixels Display Data (LSB) | | | |
| TxIN13 | 15 | B1 | Blue Pixels Display Data | | | |
| TxIN14 | 16 | B2 | Blue Pixels Display Data | | | |
| TxIN15 | 18 | B3 | Blue Pixels Display Data | TxCLK OUT- TxCLK OUT+ | No.14 No.15 | CLK- CLK+ |
| TxIN16 | 19 | B4 | Blue Pixels Display Data | | | |
| TxIN17 | 20 | B5 | Blue Pixels Display Data (MSB) | | | |
| TxIN18 | 22 | HS | Horizontal sync | | | |
| TxIN19 | 23 | VS | Vertical sync | | | |
| TxIN20 | 25 | DE | Compound Synchronization Signal | | | |
| TxCLK IN | 26 | NCLK | Data Sampling Clock | | | |

Note 1) Please connect NC pin to nothing. Don't connect it to ground nor to other signal input.

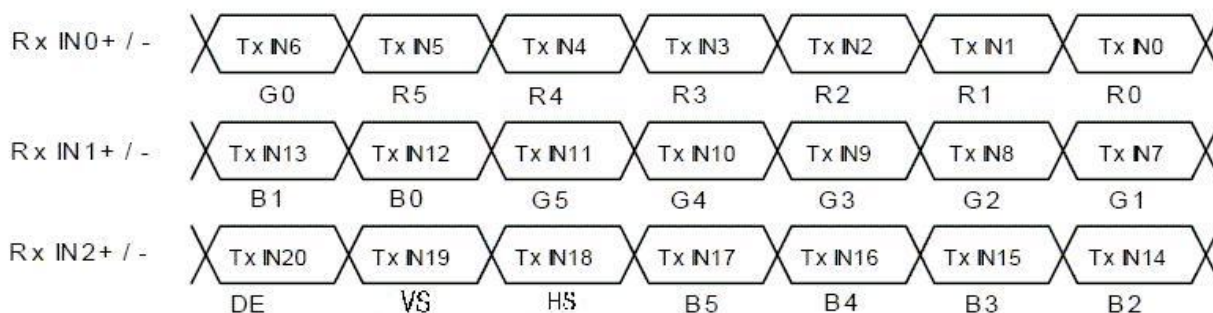

8.0 TIMING CHARACTERISTICS

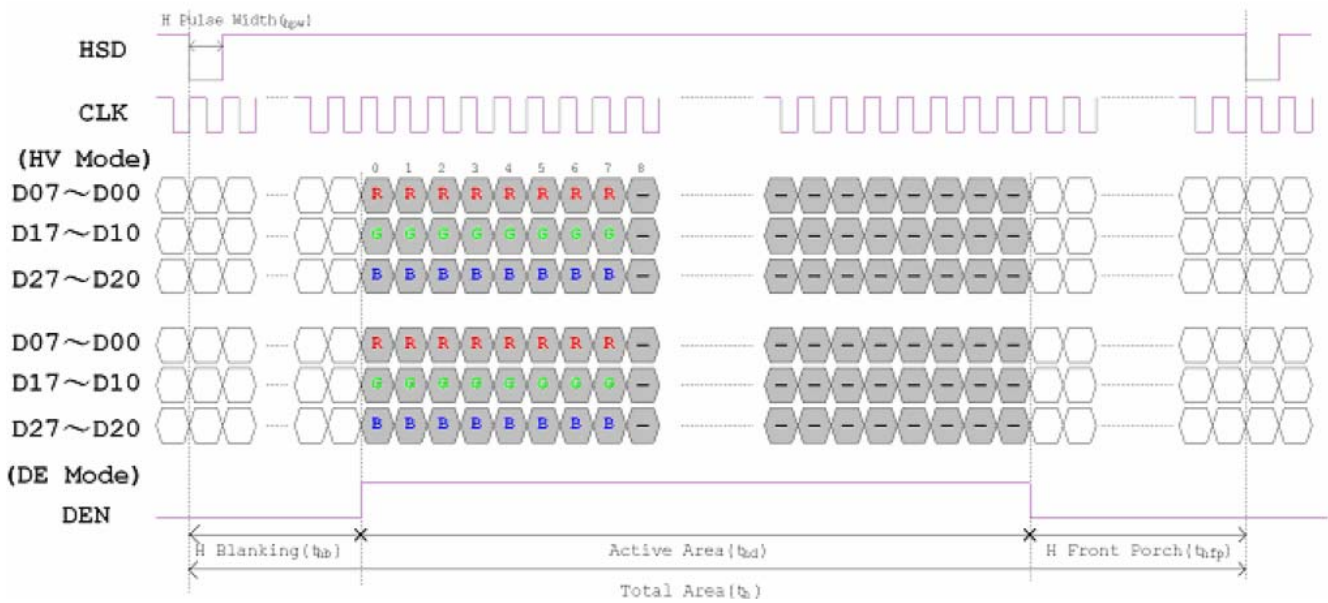
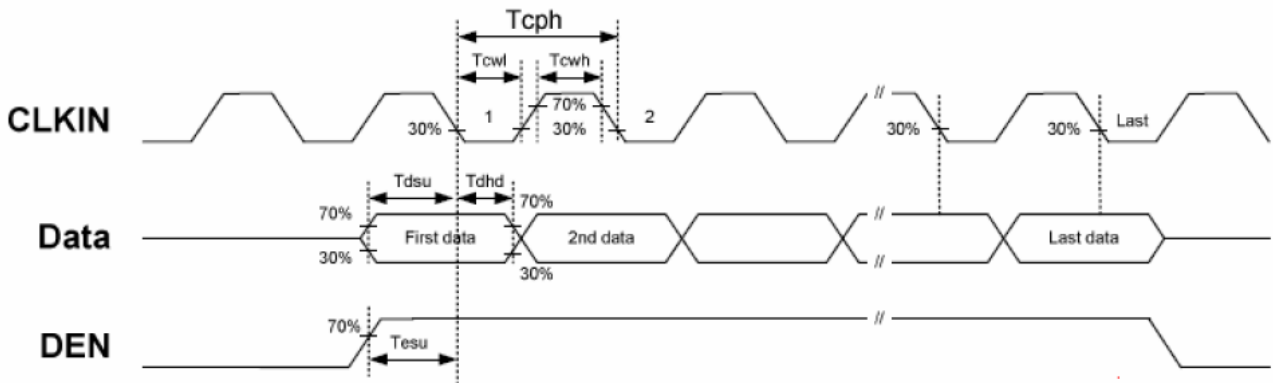

ATM0800L3A-T(AZ DISPLAYS) TFT MODULE V1.0

| Item | Symbol | Values | | | Unit | Remark |
|------------------------|-----------|--------|------|------|------|--------|
| | | Min. | Typ. | Max. | | |
| HS setup time | T_{hst} | 8 | - | - | Ns | |
| HS hold time | T_{hhd} | 8 | - | - | Ns | |
| VS setup time | T_{vst} | 8 | - | - | Ns | |
| VS hold time | T_{vhd} | 8 | - | - | Ns | |
| Data setup time | T_{dsu} | 8 | - | - | Ns | |
| Data hole time | T_{dhd} | 8 | - | - | Ns | |
| DE setup time | T_{esu} | 8 | - | - | Ns | |
| DE hole time | T_{ehd} | 8 | - | - | Ns | |
| VDD Power On Slew rate | T_{POR} | - | - | 20 | ms | |
| RSTB pulse width | T_{Rst} | 10 | - | - | us | |
| CLKIN cycle time | T_{coh} | 20 | - | - | Ns | |
| CLKIN pulse duty | T_{cwh} | 40 | 50 | 60 | % | |
| Output stable time | T_{sst} | - | - | 6 | us | |

ATM0800L3A-T(AZ DISPLAYS) TFT MODULE V1.0

| Item | Symbol | Values | | | Unit | Remark |
|-------------------------|--------|--------|------|------|------|--------|
| | | Min. | Typ. | Max. | | |
| Horizontal Display Area | thd | - | 800 | - | DCLK | |
| DCLK Frequency | fclk | - | 40 | 50 | MHz | |
| One Horizontal Line | th | 862 | 1056 | 1200 | DCLK | |
| HS pulse width | thpw | 1 | - | 40 | DCLK | |
| HS Back Porch(Blanking) | thb | 46 | 46 | 46 | DCLK | |
| HS Front Porch | thfp | 16 | 210 | 354 | DCLK | |

| Item | Symbol | Values | | | Unit | Remark |
|-------------------------|--------|--------|------|------|------|--------|
| | | Min. | Typ. | Max. | | |
| Vertical Display Area | tvd | - | 600 | - | TH | |
| VS period time | tv | 624 | 635 | 700 | TH | |
| VS pulse width | tvpw | 1 | - | 20 | TH | |
| VS Back Porch(Blanking) | tvb | 23 | 23 | 23 | TH | |
| VS Front Porch | tvfp | 1 | 12 | 77 | TH | |

9.0 RELIABILITY TEST

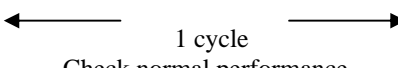
| NO | Test Item | Description | Test Condition | Remark | |
|----|----------------------------|--|---|---|----------------|
| 1 | Environmental 1 Test | High temperature storage | Applying the high storage temperature Under normal humidity for a long time Check normal performance | 80 °C 96hrs | |
| 2 | | Low temperature storage | Applying the low storage temperature Under normal humidity for a long time Check normal performance | -30°C 96hrs | |
| 3 | | High temperature Operation | Apply the electric stress(Volatge and current) Under high temperature for a long time | 70 °C 96hrs | Note1 |
| 4 | | Low temperature Operation | Apply the electric stress Under low temperature for a long time | -20°C 96hrs | Note1 Note2 |
| 5 | | High temperature/High Humidity Storage | Apply high temperature and high humidity storage for a long time | 90% RH 40°C 96hrs | Note2 |
| 6 | | Temperature Cycle | Apply the low and high temperature cycle -30°C <> 25°C <> 80°C <> 25°C 30min 10min 30min 10min  1 cycle Check normal performance | -30°C/80°C 10 cycle | |
| 7 | Mechanical Test | Vibration test(Package state) | Applying vibration to product check normal performance | Freq:10-55Hz Max Acceleration 5G 1cycle time:1min time X.Y.Z direction for 15 mines | |
| 8 | | Shock test(package state) | Applying shock to product check normal performance | Drop them through 70cm height to strike horizontal plane | |
| 9 | Other | | | | |

Remark

Note1:Normal operations condition (25°C±5°C).

Note2:Pay attention to keep dewdrops from the module during this test.

10.0 PRECAUTION FOR USING LCM

1. When design the product with this LCD Module, make sure the viewing angle matches to its purpose of usage.
2. As LCD panel is made of glass substrate, Dropping the LCD module or banging it against hard objects may cause cracking or fragmentation. Especially at corners and edges.
3. Although the polarizer of this LCD Module has the anti-glare coating, always be careful not to scratch its surface. Use of a plastic cover is recommended to protect the surface of polarizer.
4. If the LCD module is stored at below specified temperature, the LC material may freeze and be deteriorated. If it is stored at above specified temperature, the molecular orientation of the LC material may change to Liquid state and it may not revert to its original state. Excessive temperature and humidity could cause polarizer peel off or bubble. Therefore, the LCD module should always be stored within specified temperature range.
5. Saliva or water droplets must be wiped off immediately as those may leave stains or cause color changes if remained for a long time. Water vapor will cause corrosion of ITO electrodes.
6. If the surface of LCD panel needs to be cleaned, wipe it swiftly with cotton or other soft cloth. If it is not still clean enough, blow a breath on the surface and wipe again.
7. The module should be driven according to the specified ratings to avoid malfunction and permanent damage.
Applying DC voltage cause a rapid deterioration of LC material. Make sure to apply alternating waveform by continuous application of the M signal. Especially the power ON/OFF sequence should be kept to avoid latching up of driver LSIs and DC charge up to LCD panel.
8. Mechanical Considerations
 - a) LCM are assembled and adjusted with a high degree of precision. Avoid excessive shocks and do not make any alterations or modifications. The following should be noted.
 - b) Do not tamper in any way with the tabs on the metal frame.
 - c) Do not modify the PCB by drilling extra holes, changing its outline, moving its components or modifying its pattern.
 - d) Do not touch the elastomer connector; especially insert a backlight panel (for example, EL).
 - e) When mounting a LCM makes sure that the PCB is not under any stress such as bending or twisting.
Elastomer contacts are very delicate and missing pixels could result from slight dislocation of any of the elements.
 - f) Avoid pressing on the metal bezel, otherwise the elastomer connector could be deformed and lose contact, resulting in missing pixels.

9. Static Electricity

a) Operator

Wear the electrostatics shielded clothes because human body may be statically charged if not wear shielded clothes.

Never touch any of the conductive parts such as the LSI pads; the copper leads on the PCB and the interface terminals

with any parts of the human body.

b) Equipment

There is a possibility that the static electricity is charged to the equipment, which has a function of peeling or friction

ATM0800L3A-T(AZ DISPLAYS) TFT MODULE V1.0

action (ex: conveyer, soldering iron, working table). Earth the equipment through proper resistance (electrostatic

earth: 1×10^8 ohm).

Only properly grounded soldering irons should be used.

If an electric screwdriver is used, it should be well grounded and shielded from commutator sparks.

The normal static prevention measures should be observed for work clothes and working benches; for the latter

conductive (rubber) mat is recommended.

c) Floor

Floor is the important part to drain static electricity, which is generated by operators or equipment.

There is a possibility that charged static electricity is not properly drained in case of insulating floor. Set the electrostatic earth (electrostatic earth: 1×10^8 ohm).

d) Humidity

Proper humidity helps in reducing the chance of generating electrostatic charges. Humidity should be kept over

50%RH.

e) Transportation/storage

The storage materials also need to be anti-static treated because there is a possibility that the human body or storage

materials such as containers may be statically charged by friction or peeling.

The modules should be kept in antistatic bags or other containers resistant to static for storage.

f) Soldering

Solder only to the I/O terminals. Use only soldering irons with proper grounding and no leakage.

Soldering temperature : $280^{\circ} \text{C} \pm 10^{\circ} \text{C}$

Soldering time: 3 to 4 sec.

Use eutectic solder with resin flux fill.

If flux is used, the LCD surface should be covered to avoid flux spatters. Flux residue should be removed afterwards.

g) Others

The laminator (protective film) is attached on the surface of LCD panel to prevent it from scratches or stains. It should

be peeled off slowly using static eliminator.

Static eliminator should also be installed to the workbench to prevent LCD module from static charge.

10. Operation

a) Driving voltage should be kept within specified range; excess voltage shortens display life.

b) Response time increases with decrease in temperature.

c) Display may turn black or dark blue at temperatures above its operational range; this is (however not pressing on the viewing area) may cause the segments to appear "fractured".

d) Mechanical disturbance during operation (such as pressing on the viewing area) may cause the segments to appear "fractured".

ATM0800L3A-T(AZ DISPLAYS) TFT MODULE V1.0

11. If any fluid leaks out of a damaged glass cell, wash off any human part that comes into contact with soap and water. The toxicity is extremely low but caution should be exercised at all the time.
12. Disassembling the LCD module can cause permanent damage and it should be strictly avoided.
13. LCD retains the display pattern when it is applied for long time (Image retention). To prevent image retention, do not apply the fixed pattern for a long time. Image retention is not a deterioration of LCD. It will be removed after display pattern is changed.
14. Do not use any materials, which emit gas from epoxy resin (hardener for amine) and silicone adhesive agent (dealcohol or deoxym) to prevent discoloration of polarizer due to gas.
15. Avoid the exposure of the module to the direct sunlight or strong ultraviolet light for a long time.
16. The brightness of LCD module may be affected by the routing of CCFL cables due to leakage to the chassis through coupling effect. The inverter circuit needs to be designed taking the level of leakage current into consideration. Thorough evaluation is needed for LCD module and inverter built into its host equipment to ensure specified brightness.