

## CCO-014S & 014 Models

8 & 14 Pin Dip, 5V, HCMOS/TTL

<b>Frequency Range:</b>	1.544MHz to 156.250MHz
<b>Frequency Stability:</b>	±20ppm to ±100ppm
<b>Temperature Range:</b>	
Operating:	0°C to 70°C
(Option M)	-20°C to 70°C
(Option X)	-40°C to 85°C
<b>Storage:</b>	-45°C to 90°C
<b>Input Voltage:</b>	5V ±0.5V
<b>Input Current:</b>	60mA Max
<b>Output:</b>	HCMOS/TTL
Symmetry:	40/60% Max @ 50% Vdd
(Option Y)	45/55% Max
Rise/Fall Time:	4ns Typ, 10ns Max
Logic:	"0" = 10% Vdd Max "1" = 90% Vdd Min
Load:	15pF/10TTL Max 50pF/10TTL Max



Designed to meet today's requirements for economical solutions.

### CCO-014S

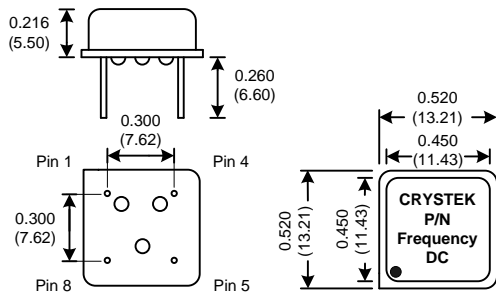

### CCO-014

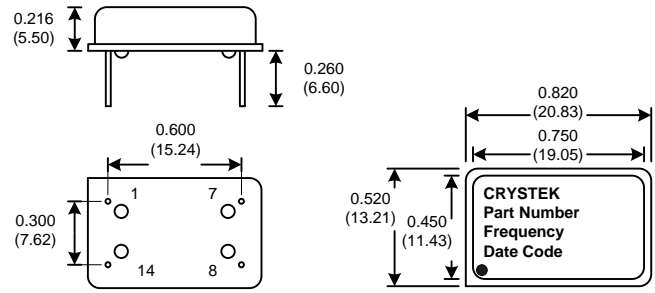

Dimensions inches (mm)

All dimensions are Max unless otherwise specified.

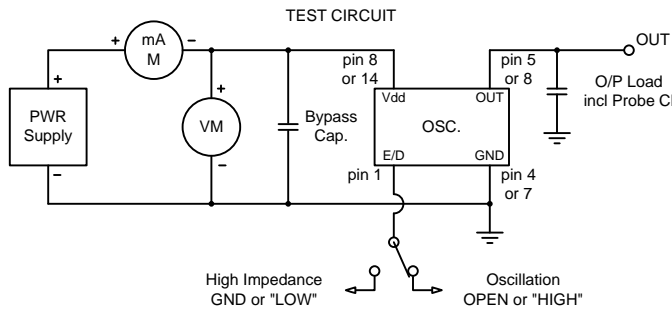

Tri-State Function	
Function pin 1	Output pin
Open	Active
"1" level 2.4V Min	Active
"0" level 0.4V Max	High Z

### Crystek Part Number Guide

CCO-014 T X Y H- 25 - 49.152

#1 #2 #3 #4 #5 #6 #7 #8

#1 Crystek Clock Osc.  
#2 Model (014 or 014S)  
#3 Tristate: Blank= no Tristate, T= Tristate  
#4 Temp. Range: Blank= 0/70°C, M= -20/70°C, X= -40/85°C  
#5 Symmetry: Blank=(40/60), Y=(45/55)  
#6 Load: Blank= standard, H= 50pF  
#7 Stability: (see Table 1)  
#8 Frequency in MHz: 3 or 6 decimal places

Stability Indicator:	0/70	-40/85
	-20/70	
Blank (std)	±100ppm	**
50	± 50ppm	**
25	± 25ppm	**
20	± 20ppm	**

Table 1

Example:

CCO-014TXY-25-25.000 = (full size) 5.0V Tristate, -40/85°C, 45/55, 25ppm, 25.000 MHz  
CCO-014ST-50-19.660800 = (half size) 5.0V Tristate, 0/70, 40/60, 50ppm, 19.660800 MHz

Specifications subject to change without notice.

TD-02075 Rev. H