

### General Description

This Trench MOSFET has better characteristics, such as fast switching time, low on resistance, low gate charge and excellent avalanche characteristics. It is mainly suitable for LED Lighting and DC/DC Converters.

### FEATURES

- $V_{DSS(Min.)} = 100V$ ,  $I_D = 1.7A$
- Drain-Source ON Resistance :  $R_{DS(ON)} = 0.36 \Omega$  (max) @  $V_{GS} = 10V$
- $Qg(\text{typ.}) = 4.2nC$

### MAXIMUM RATING (Tc=25°C)

CHARACTERISTIC	SYMBOL	RATING	UNIT
Drain-Source Voltage	$V_{DSS}$	100	V
Gate-Source Voltage	$V_{GSS}$	± 20	V
Drain Current	@T <sub>C</sub> =25°C	$I_D$	1.7*
	@T <sub>C</sub> =100°C		1.0*
	Pulsed (Note1)	$I_{DP}$	6.4*
Single Pulsed Avalanche Energy (Note 2)	$E_{AS}$	12.4	mJ
Repetitive Avalanche Energy (Note 1)	$E_{AR}$	0.1	mJ
Peak Diode Recovery dv/dt (Note 3)	dv/dt	4.5	V/ns
Drain Power Dissipation	T <sub>A</sub> =25°C	$P_D$	2.0*
	Derate above 25°C		0.016
Maximum Junction Temperature	T <sub>j</sub>	150	°C
Storage Temperature Range	T <sub>stg</sub>	-55 ~ 150	°C
<b>Thermal Characteristics</b>			
Thermal Resistance, Junction-to-Ambient	R <sub>thJA</sub>	62.5*	°C/W

\* : Surface Mounted on FR4 Board (50mm×50mm, 1.0t)

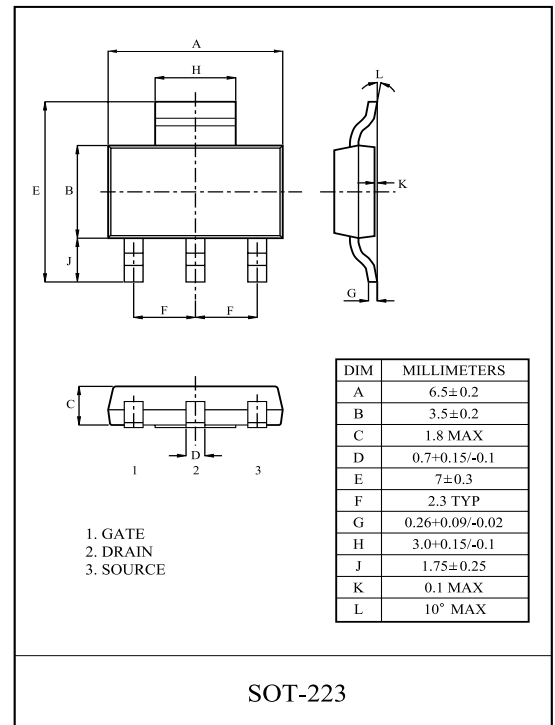

### PIN CONNECTION

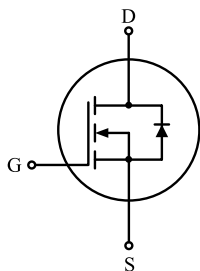

# KU3600N10W

## ELECTRICAL CHARACTERISTICS (T<sub>c</sub>=25°C)

CHARACTERISTIC	SYMBOL	TEST CONDITION	MIN.	TYP.	MAX.	UNIT
<b>Static</b>						
Drain-Source Breakdown Voltage	BV <sub>DSS</sub>	I <sub>D</sub> =250μA, V <sub>GS</sub> =0V	100	-	-	V
Breakdown Voltage Temperature Coefficient	Δ BV <sub>DSS</sub> /Δ T <sub>j</sub>	I <sub>D</sub> =250μA, Referenced to 25°C	-	0.1	-	V/°C
Drain Cut-off Current	I <sub>DSS</sub>	V <sub>DS</sub> =100V, V <sub>GS</sub> =0V,	-	-	10	μA
Gate Threshold Voltage	V <sub>th</sub>	V <sub>DS</sub> =V <sub>GS</sub> , I <sub>D</sub> =250μA	2.0	-	4.0	V
Gate Leakage Current	I <sub>GSS</sub>	V <sub>GS</sub> =± 20V, V <sub>DS</sub> =0V	-	-	± 100	nA
Drain-Source ON Resistance	R <sub>DS(ON)</sub>	V <sub>GS</sub> =10V, I <sub>D</sub> =0.8A	-	0.30	0.36	Ω
		V <sub>GS</sub> =6V, I <sub>D</sub> =0.8A		-	0.40	
<b>Dynamic</b>						
Total Gate Charge	Q <sub>g</sub>	V <sub>DS</sub> =80V, I <sub>D</sub> =1.7A V <sub>GS</sub> =10V (Note4,5)	-	4.2	5.5	nC
Gate-Source Charge	Q <sub>gs</sub>		-	1.0	-	
Gate-Drain Charge	Q <sub>gd</sub>		-	1.5	-	
Turn-on Delay time	t <sub>d(on)</sub>	V <sub>DD</sub> =50V, I <sub>D</sub> =1.7A R <sub>G</sub> =25Ω (Note4,5) V <sub>GS</sub> =10V	-	20	-	ns
Turn-on Rise time	t <sub>r</sub>		-	15	-	
Turn-off Delay time	t <sub>d(off)</sub>		-	50	-	
Turn-off Fall time	t <sub>f</sub>		-	10	-	
Input Capacitance	C <sub>iss</sub>	V <sub>DS</sub> =25V, V <sub>GS</sub> =0V, f=1.0MHz	-	230	320	pF
Output Capacitance	C <sub>oss</sub>		-	25	-	
Reverse Transfer Capacitance	C <sub>rss</sub>		-	9.0	-	
<b>Source-Drain Diode Ratings</b>						
Continuous Source Current	I <sub>S</sub>	V <sub>GS</sub> <V <sub>th</sub>	-	-	1	A
Pulsed Source Current	I <sub>SP</sub>		-	-	4	
Diode Forward Voltage	V <sub>SD</sub>	I <sub>S</sub> =1.7A, V <sub>GS</sub> =0V	-	-	1.4	V
Reverse Recovery Time	t <sub>rr</sub>	I <sub>S</sub> =1.7A, V <sub>GS</sub> =0V, dI <sub>S</sub> /dt=100A/μs	-	60	-	ns
Reverse Recovery Charge	Q <sub>rr</sub>		-	0.10	-	μC

Note 1) Repetivity rating : Pulse width limited by junction temperature.

Note 2) L = 5mH, I<sub>S</sub>=1.7A, V<sub>DD</sub>=50V, R<sub>G</sub> = 25Ω , Starting T<sub>j</sub> = 25°C.

Note 3) I<sub>S</sub> ≤ 1.7A, dI/dt ≤ 300A/μs, V<sub>DD</sub> ≤ BV<sub>DSS</sub>, Starting T<sub>j</sub> = 25°C.

Note 4) Pulse Test : Pulse width ≤ 300μs, Duty Cycle ≤ 2%.

Note 5) Essentially independent of operating temperature.

### Marking

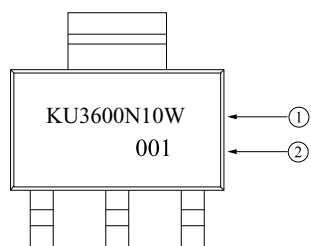

① PRODUCT NAME

② LOT NO

# KU3600N10W

Fig1.  $I_D - V_{DS}$

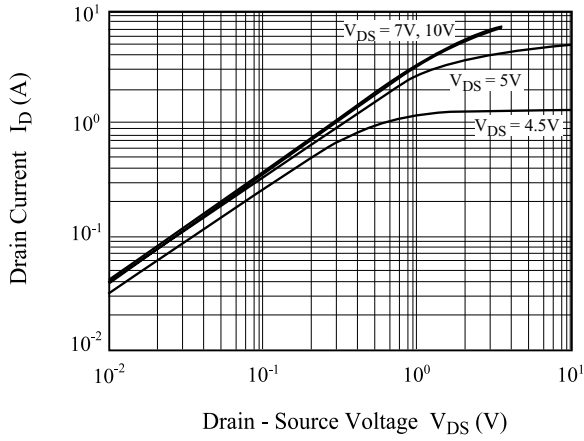

Fig2.  $I_D - V_{GS}$

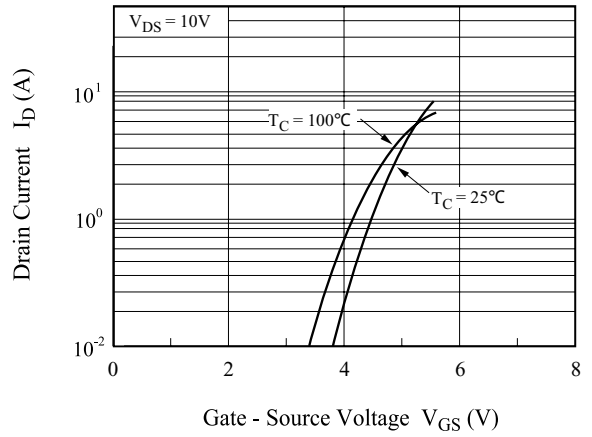

Fig3.  $BV_{DSS} - T_j$

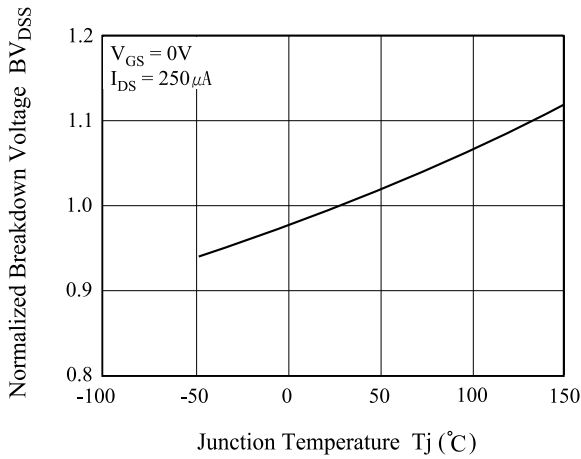

Fig4.  $R_{DS(ON)} - I_D$

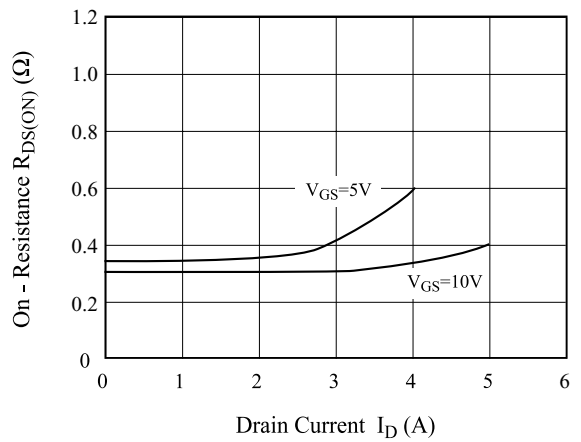

Fig5.  $I_S - V_{SD}$

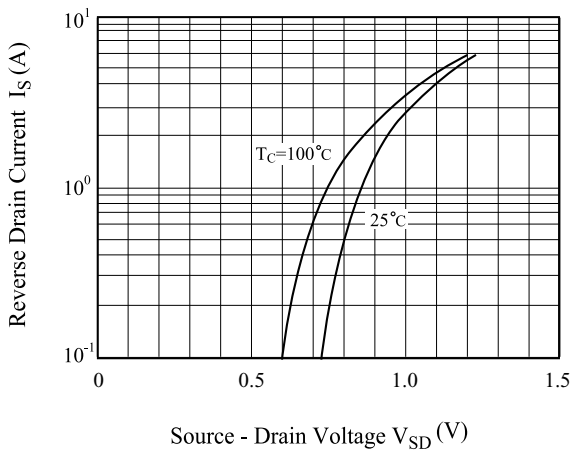
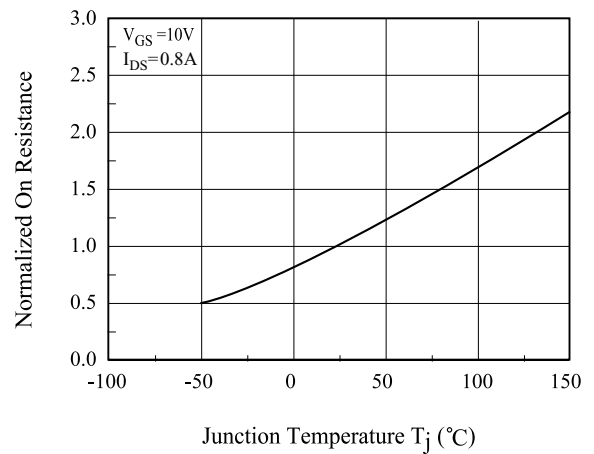

Fig6.  $R_{DS(ON)} - T_j$



# KU3600N10W

Fig 7. C - V<sub>DS</sub>

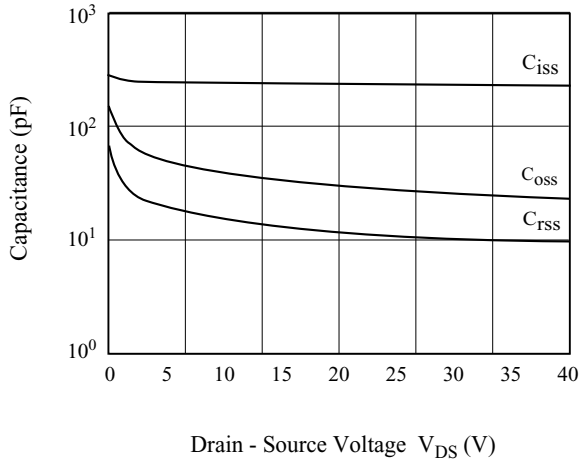

Fig8. Q<sub>g</sub>- V<sub>GS</sub>

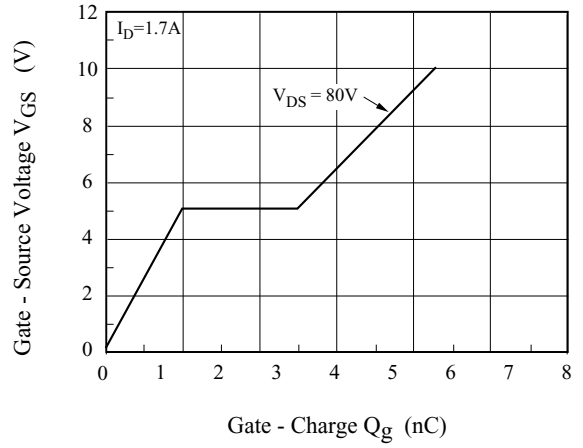

Fig9. Safe Operation Area

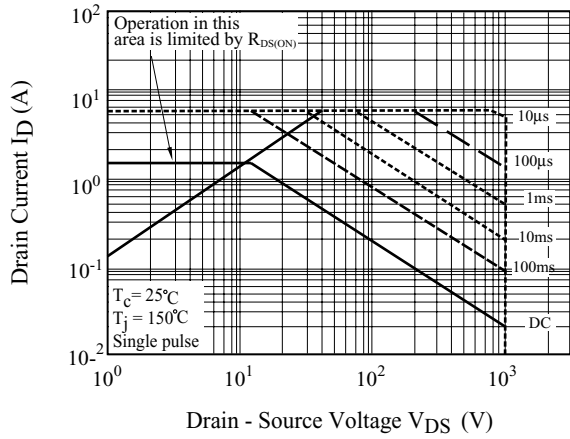

Fig10. I<sub>D</sub> - T<sub>j</sub>

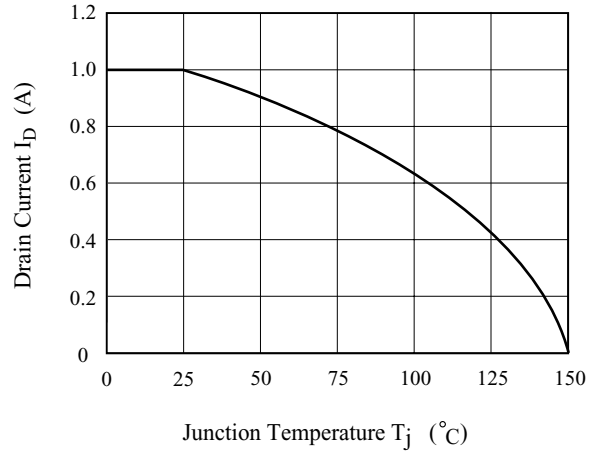

Fig11. Transient Thermal Response Curve

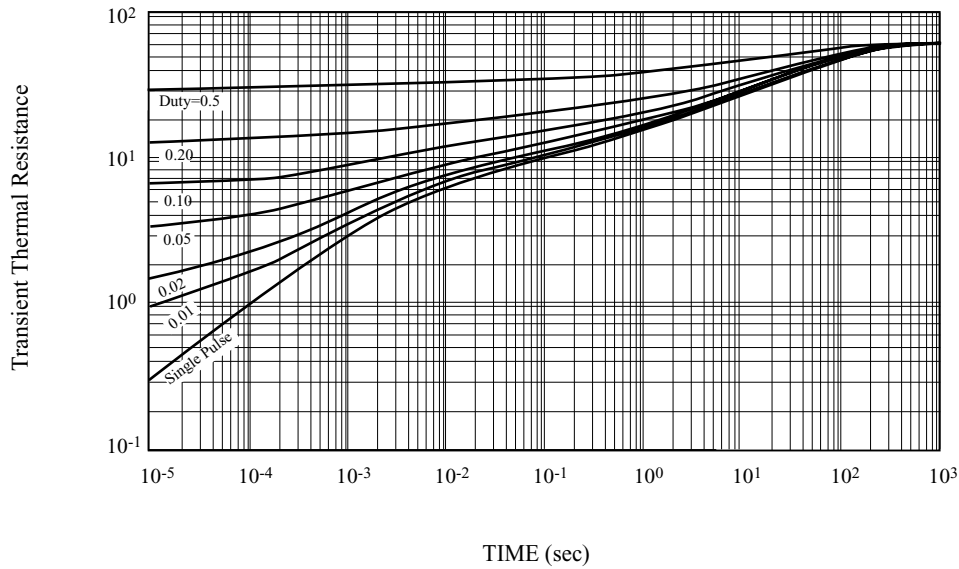

Fig12. Gate Charge

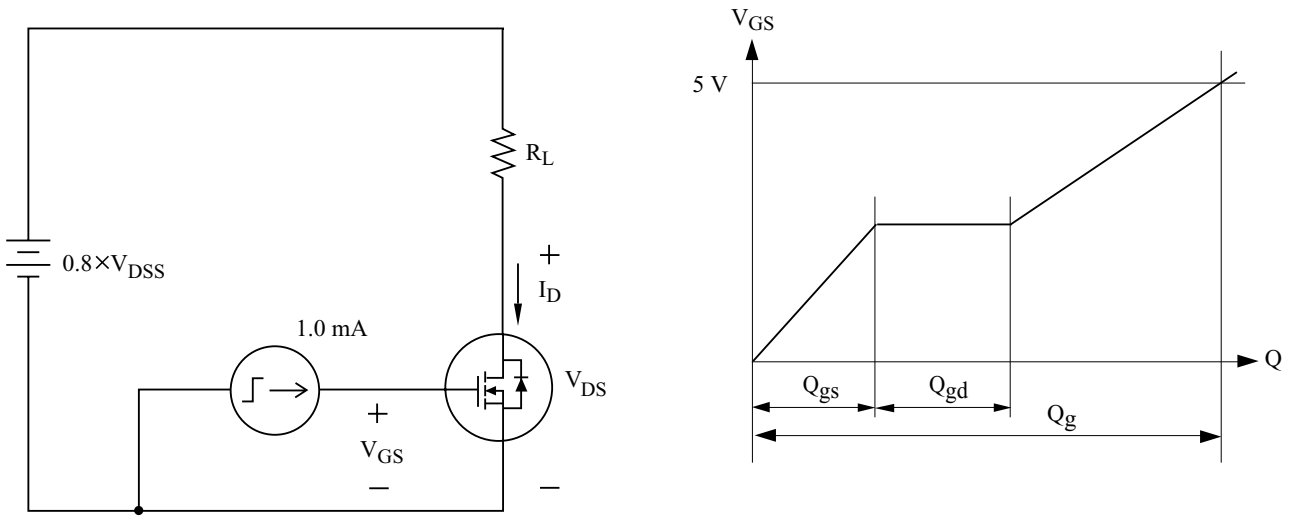

Fig13. Single Pulsed Avalanche Energy

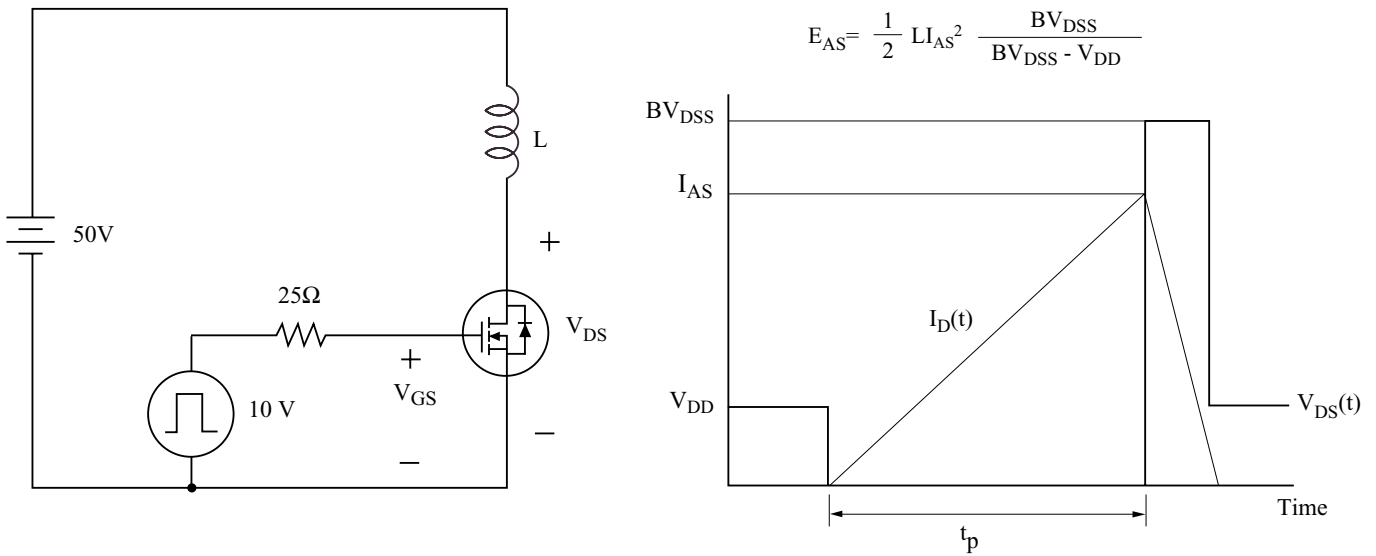

Fig14. Resistive Load Switching

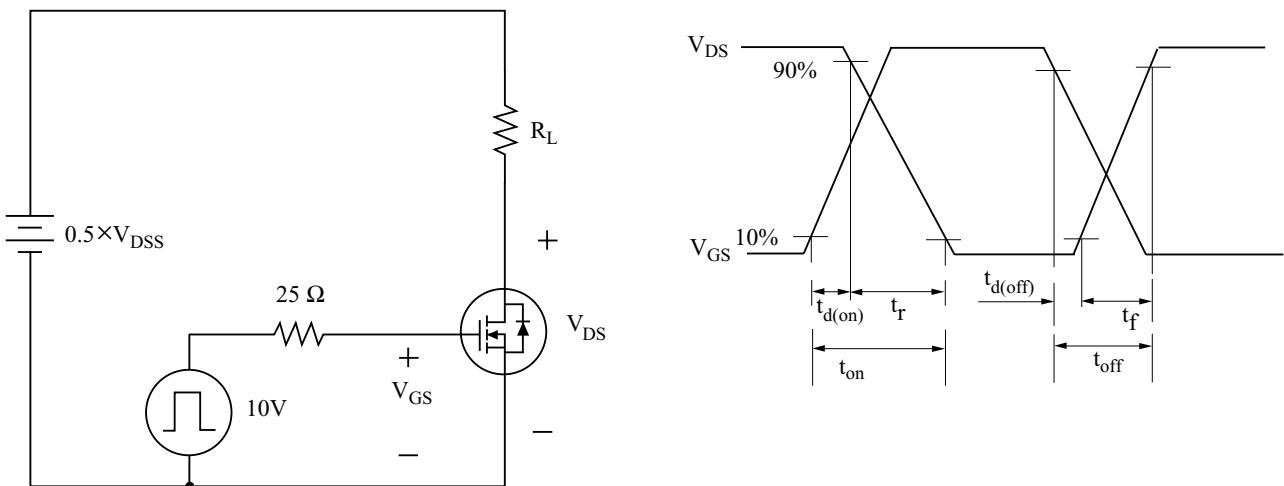

Fig15. Source - Drain Diode Reverse Recovery and  $dv/dt$

