



Package 1 Size: 0.60 x 0.31 x 0.29 inches  
 Package 2 Size: 0.60 x 0.31 x 0.33 inches  
 Weight: 0.06oz (1.8g)

**FEATURES**

- 1 Watt Output Power
- RoHS Compliant
- Unregulated Single & Dual Outputs
- High I/O Isolation: 3000VDC
- No External Components Required
- -40°C to +85°C Operating Temperature
- 22-PIN SMT Package and Industry Standard Pin-out
- High Efficiency up to 80%
- Recognized by UL60950-1
- MTBF > 3,500,000 Hours

**DESCRIPTION**

The RC series of 1 watt DC/DC power converters are specially designed to provide high levels of isolation in a 22-PIN SMT package. This series consists of 50 models with nominal input voltages of 3.3V, 5V, 9V, 12V, and 15V and standard unregulated output voltages of 3.3V, 5V, 9V, 12V, and 15V in both single and dual output configurations. The RC series is highly suitable for high speed SMT pick-and-place machine operation. The operating temperature range of -40°C to +85°C is ideal for designers requiring industrial temperature operation. The RC series is RoHS compliant and has UL60950-1 safety approvals.

**SPECIFICATIONS: RC SERIES**

All specifications are based on 25°C, Nominal Input Voltage, and Maximum Output Current unless otherwise noted.  
 We reserve the right to change specifications based on technological advances.

SPECIFICATION	TEST CONDITIONS	Min	Typ	Max	Unit
<b>INPUT SPECIFICATIONS</b>					
Input Voltage Range	3.3VDC nominal input models	2.97	3.3	3.63	VDC
	5VDC nominal input models	4.5	5	5.5	
	9VDC nominal input models	8.1	9	9.9	
	12VDC nominal input models	10.8	12	13.2	
	15VDC nominal input models	13.5	15	16.5	
Input Filter		capacitor			
<b>OUTPUT SPECIFICATIONS</b>					
Output Voltage		See Table			
Output Voltage Tolerance	100% full load			±5	%
Line Regulation	For Vin change of 1%		1.2		%
Load Regulation	10% to 100% full load	3.3 VDC output models	15		%
		5VDC output models		12	
		9VDC output models		8.0	
		12 VDC output models		8.5	
		15VDC output models		7.0	
Output Current		See Table			
Output Power				1	W
Minimum Load		10			%
Ripple & Noise	20MHz limited bandwidth			75	mVp-p
Transient Response Setting Time	50% load step change		350		µs
<b>PROTECTION</b>					
Short Circuit Protection		none			
<b>GENERAL SPECIFICATIONS</b>					
Efficiency		See Table			
Switching Frequency	Nominal input and full load		100		KHz
Isolation Voltage (Input to Output)		3000			VDC
Isolation Resistance	500VDC	1000			MΩ
<b>ENVIRONMENTAL SPECIFICATIONS</b>					
Operating Ambient Temperature	See derating curve	-40		+85	°C
Humidity	Non-condensing			95	% RH
Cooling		Free air convection			
MTBF	MIL-HDBK-217F at 25°C, ground benign	3,500,000			hours
<b>PHYSICAL SPECIFICATIONS</b>					
Case Material		DAP			
Weight	Package 1 & Package 2	0.06oz (1.8g)			
Dimensions (L x W x H)	Package 1	0.60 x 0.31 x 0.29 inches (15.24 x 8.0 x 7.30 mm)			
	Package 2	0.60 x 0.31 x 0.33 inches (15.24 x 8.0 x 8.50 mm)			
<b>SAFETY</b>					
Safety Approvals		UL60950-1			

\*Due to advances in technology, specifications subject to change without notice.

**MODEL SELECTION TABLE**

**SINGLE OUTPUT MODELS**

Model Number	Input Voltage	Output Voltage	Output Current		Load Reg.	Ripple & Noise	Output Power	Efficiency <sup>(2)</sup>	Package Type
			Min <sup>(1)</sup>	Max					
RC33S33-303NH	3.3 VDC (2.97 - 3.63 VDC)	3.3 VDC	30.3mA	303mA	15%	75mVp-p	1W	65%	1
RC33S5-200NH		5 VDC	20mA	200mA	12%	75mVp-p	1W	70%	1
RC33S9-112NH		9 VDC	11.2mA	112mA	8.0%	75mVp-p	1W	75%	1
RC33S12-83NH		12 VDC	8.4mA	84mA	8.5%	75mVp-p	1W	78%	2
RC33S15-67NH		15 VDC	6.7mA	67mA	7.0%	75mVp-p	1W	80%	2
RC5S33-303NH	5 VDC (4.5 - 5.5 VDC)	3.3 VDC	30.3mA	303mA	15%	75mVp-p	1W	65%	1
RC5S5-200NH		5 VDC	20mA	200mA	12%	75mVp-p	1W	70%	1
RC5S9-112NH		9 VDC	11.2mA	112mA	8.0%	75mVp-p	1W	75%	1
RC5S12-83NH		12 VDC	8.4mA	84mA	8.5%	75mVp-p	1W	78%	2
RC5S15-67NH		15 VDC	6.7mA	67mA	7.0%	75mVp-p	1W	80%	2
RC9S33-303NH	9 VDC (8.1 - 9.9 VDC)	3.3 VDC	30.3mA	303mA	15%	75mVp-p	1W	65%	1
RC9S5-200NH		5 VDC	20mA	200mA	12%	75mVp-p	1W	70%	1
RC9S9-112NH		9 VDC	11.2mA	112mA	8.0%	75mVp-p	1W	75%	1
RC9S12-83NH		12 VDC	8.4mA	84mA	8.5%	75mVp-p	1W	78%	2
RC9S15-67NH		15 VDC	6.7mA	67mA	7.0%	75mVp-p	1W	80%	2
RC12S33-303NH	12 VDC (10.8 - 13.2 VDC)	3.3 VDC	30.3mA	303mA	15%	75mVp-p	1W	65%	2
RC12S5-200NH		5 VDC	20mA	200mA	12%	75mVp-p	1W	70%	2
RC12S9-112NH		9 VDC	11.2mA	112mA	8.0%	75mVp-p	1W	75%	2
RC12S12-83NH		12 VDC	8.4mA	84mA	8.5%	75mVp-p	1W	78%	2
RC12S15-67NH		15 VDC	6.7mA	67mA	7.0%	75mVp-p	1W	80%	2
RC24S33-303NH	15 VDC (13.5 - 16.5 VDC)	3.3 VDC	30.3mA	303mA	15%	75mVp-p	1W	65%	2
RC24S5-200NH		5 VDC	20mA	200mA	12%	75mVp-p	1W	70%	2
RC24S9-112NH		9 VDC	11.2mA	112mA	8.0%	75mVp-p	1W	75%	2
RC24S12-83NH		12 VDC	8.4mA	84mA	8.5%	75mVp-p	1W	78%	2
RC24S15-67NH		15 VDC	6.7mA	67mA	7.0%	75mVp-p	1W	80%	2

**DUAL OUTPUT MODELS**

Model Number	Input Voltage	Output Voltage	Output Current		Load Reg.	Ripple & Noise	Output Power	Efficiency <sup>(2)</sup>	Package Type
			Min <sup>(1)</sup>	Max					
RC33D33-150NH	3.3 VDC (2.97 - 3.63 VDC)	±3.3 VDC	±15mA	±150mA	15%	75mVp-p	1W	65%	1
RC33D5-100NH		±5 VDC	±10mA	±100mA	12%	75mVp-p	1W	70%	1
RC33D9-55NH		±9 VDC	±5.6mA	±56mA	8.0%	75mVp-p	1W	75%	1
RC33D12-42NH		±12 VDC	±4.2mA	±42mA	8.5%	75mVp-p	1W	78%	2
RC33D15-33NH		±15 VDC	±3.4mA	±34mA	7.0%	75mVp-p	1W	80%	2
RC5D33-150NH	5 VDC (4.5 - 5.5 VDC)	±3.3 VDC	±15mA	±150mA	15%	75mVp-p	1W	65%	1
RC5D5-100NH		±5 VDC	±10mA	±100mA	12%	75mVp-p	1W	70%	1
RC5D9-55NH		±9 VDC	±5.6mA	±56mA	8.0%	75mVp-p	1W	75%	1
RC5D12-42NH		±12 VDC	±4.2mA	±42mA	8.5%	75mVp-p	1W	78%	2
RC5D15-33NH		±15 VDC	±3.4mA	±34mA	7.0%	75mVp-p	1W	80%	2
RC9D33-150NH	9 VDC (8.1 - 9.9 VDC)	±3.3 VDC	±15mA	±150mA	15%	75mVp-p	1W	65%	1
RC9D5-100NH		±5 VDC	±10mA	±100mA	12%	75mVp-p	1W	70%	1
RC9D9-55NH		±9 VDC	±5.6mA	±56mA	8.0%	75mVp-p	1W	75%	1
RC9D12-42NH		±12 VDC	±4.2mA	±42mA	8.5%	75mVp-p	1W	78%	2
RC9D15-33NH		±15 VDC	±3.4mA	±34mA	7.0%	75mVp-p	1W	80%	2
RC12D33-150NH	12 VDC (10.8 - 13.2 VDC)	±3.3 VDC	±15mA	±150mA	15%	75mVp-p	1W	65%	2
RC12D5-100NH		±5 VDC	±10mA	±100mA	12%	75mVp-p	1W	70%	2
RC12D9-55NH		±9 VDC	±5.6mA	±56mA	8.0%	75mVp-p	1W	75%	2
RC12D12-42NH		±12 VDC	±4.2mA	±42mA	8.5%	75mVp-p	1W	78%	2
RC12D15-33NH		±15 VDC	±3.4mA	±34mA	7.0%	75mVp-p	1W	80%	2
RC15D33-150NH	15 VDC (13.5 - 16.5 VDC)	±3.3 VDC	±15mA	±150mA	15%	75mVp-p	1W	65%	2
RC15D5-100NH		±5 VDC	±10mA	±100mA	12%	75mVp-p	1W	70%	2
RC15D9-55NH		±9 VDC	±5.6mA	±56mA	8.0%	75mVp-p	1W	75%	2
RC15D12-42NH		±12 VDC	±4.2mA	±42mA	8.5%	75mVp-p	1W	78%	2
RC15D15-33NH		±15 VDC	±3.4mA	±34mA	7.0%	75mVp-p	1W	80%	2

**NOTES**

1. The RC series requires a ±10% minimum output load to maintain all specified regulations.
2. As the input voltage increases, the efficiency will also increase.

RECOMMENDED TEST CIRCUITS

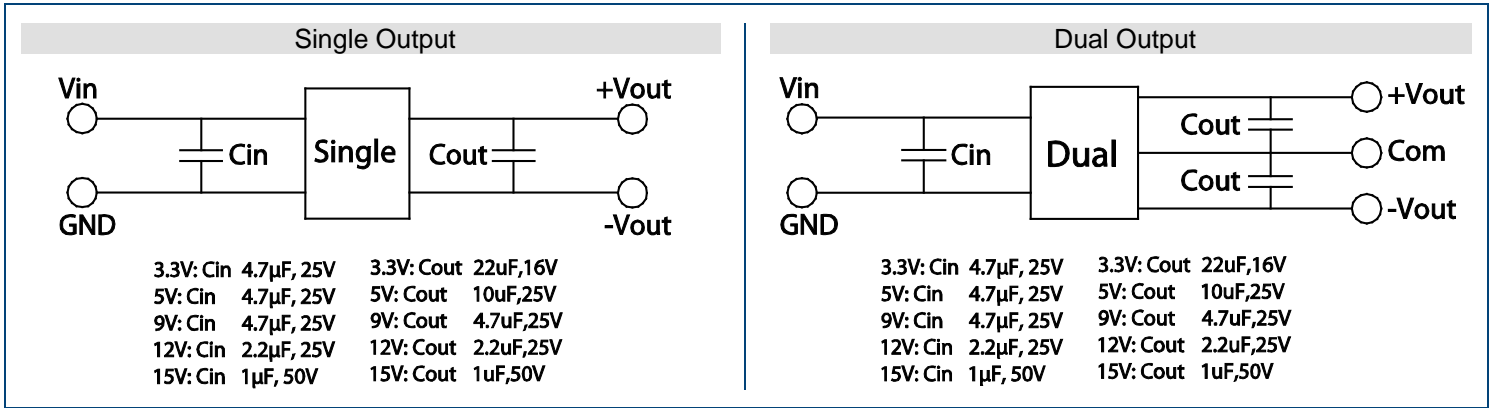

CHARACTERISTIC CURVES

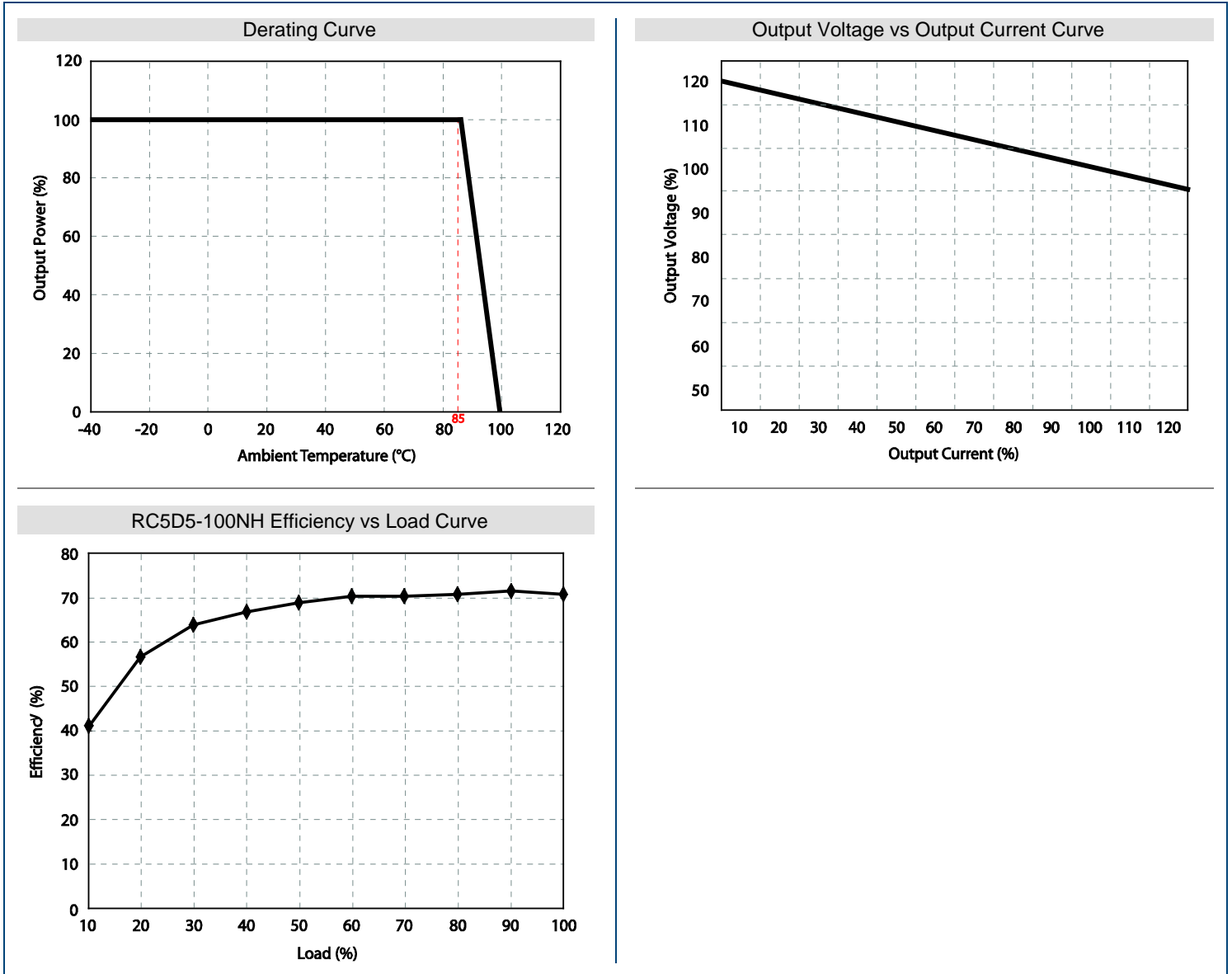

MECHANICAL DRAWINGS

Package 1

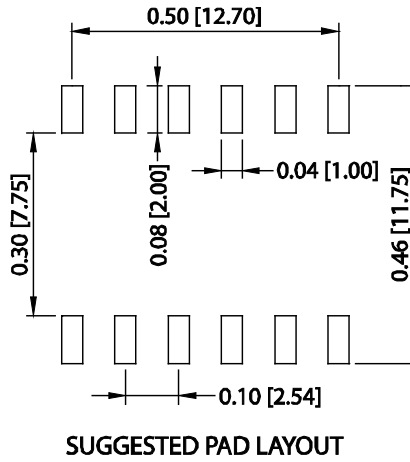
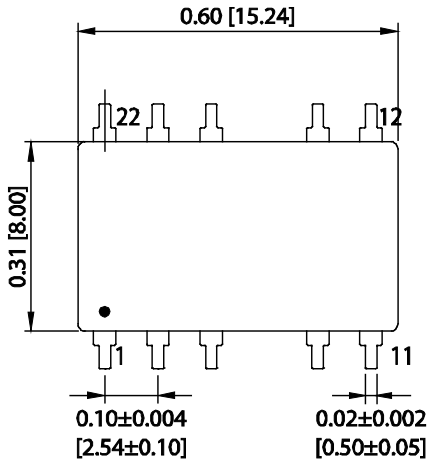

Notes

1. Unit: inches [mm]
2. Tolerance:  $\pm 0.01$  [ $\pm 0.25$ ]
3. Case Material: DAP
4. Weight: 0.06oz (1.8g)

PIN CONNECTIONS		
Pin	Single	Dual
1	-Vin	-Vin
3	+Vin	+Vin
5	NC	NC
9	-Vout	Com
11	NC	-Vout
12	NC	NC
14	+Vout	+Vout
18	NC	NC
20	NC	NC
22	NC	NC

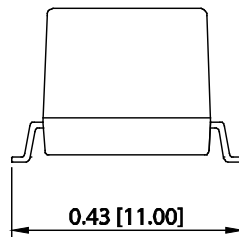
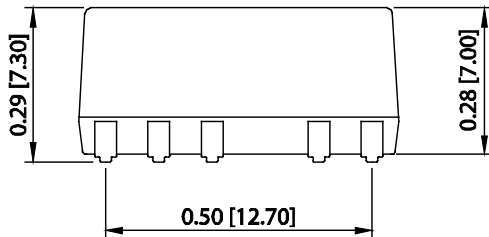

Package 2

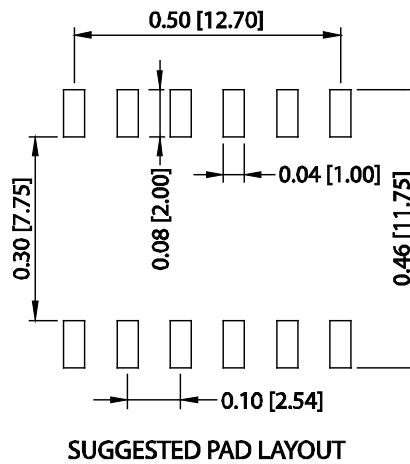
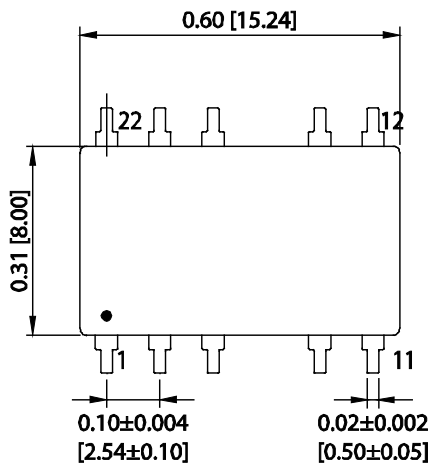

Notes

1. Unit: inches [mm]
2. Tolerance:  $\pm 0.01$  [ $\pm 0.25$ ]
3. Case Material: DAP
4. Weight: 0.06oz (1.8g)

PIN CONNECTIONS		
Pin	Single	Dual
1	-Vin	-Vin
3	+Vin	+Vin
5	NC	NC
9	-Vout	Com
11	NC	-Vout
12	NC	NC
14	+Vout	+Vout
18	NC	NC
20	NC	NC
22	NC	NC

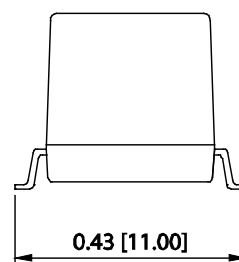
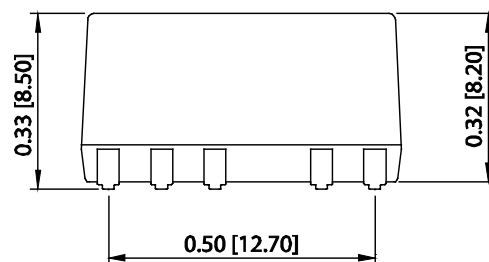

**SOLDER DETAILS**

RoHS parts can withstand IR Reflow peak temperature: 240°C Max as the following profile.

Profile Feature	Pb-Free Assembly
Average Ramp-Up Rate (Ts <sub>max</sub> to Tp)	3°C/second max.
<b>Preheat</b>	
-Temperature Min (Ts <sub>min</sub> )	150°C
-Temperature Max (Ts <sub>max</sub> )	200°C
-Time (ts <sub>min</sub> to ts <sub>max</sub> )	60-180 seconds
<b>Time Maintained Above:</b>	
-Temperature (T <sub>L</sub> )	217°C
-Time (t <sub>L</sub> )	60-150 seconds
Peak/Classification Temperature (Tp)	240°C MAX
Time within 5°C of actual peak Temperature (tp)	20-40 seconds
Ramp-Down Rate	6°C/seconds max.
Time 25°C to Peak Temperature	6 minutes max.

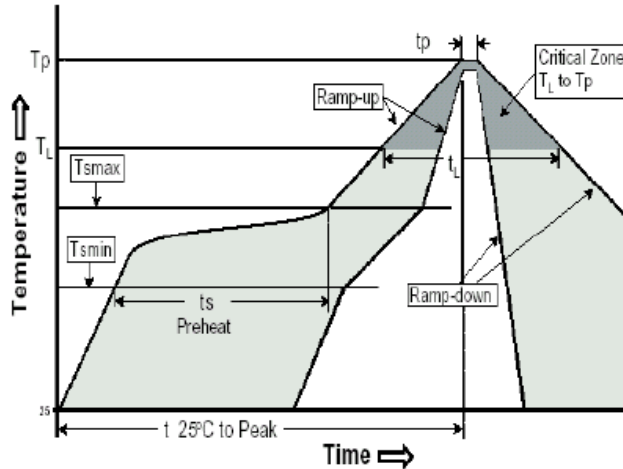

**MODEL NUMBER SETUP**

RC	15	S	15	-	67	N	H
Series Name	Input Voltage	Output Quantity	Ouput Voltage		Output Current	Unregulated	I/O Isolation
	<b>33:</b> 3.3 VDC <b>5:</b> 5 VDC <b>9:</b> 9 VDC <b>12:</b> 12 VDC <b>15:</b> 15 VDC	<b>S:</b> Single Output	<b>33:</b> 3.3 VDC <b>5:</b> 5 VDC <b>9:</b> 9 VDC <b>12:</b> 12 VDC <b>15:</b> 15 VDC		<b>303:</b> 303mA <b>200:</b> 200mA <b>112:</b> 112mA <b>83:</b> 83mA <b>67:</b> 67mA	<b>N:</b> Unregulated	<b>H:</b> 3000VDC
		<b>D:</b> Dual Output	<b>33:</b> ±3.3 VDC <b>5:</b> ±5 VDC <b>9:</b> ±9 VDC <b>12:</b> ±12 VDC <b>15:</b> ±15 VDC		<b>150:</b> ±150mA <b>100:</b> ±100mA <b>55:</b> ±56mA <b>42:</b> ±42mA <b>33:</b> ±34mA		

---

**COMPANY INFORMATION**

---

Wall Industries, Inc. has created custom and modified units for over 50 years. Our in-house research and development engineers will provide a solution that exceeds your performance requirements on-time and on budget. Our ISO9001-2008 certification is just one example of our commitment to producing a high quality, well-documented product for our customers.

Our past projects demonstrate our commitment to you, our customer. Wall Industries, Inc. has a reputation for working closely with its customers to ensure each solution meets or exceeds form, fit and function requirements. We will continue to provide ongoing support for your project above and beyond the design and production phases. Give us a call today to discuss your future projects.

Contact **Wall Industries** for further information:

Phone:	☎ (603)778-2300
Toll Free:	☎ (888)597-9255
Fax:	☎ (603)778-9797
E-mail:	<a href="mailto:sales@wallindustries.com">sales@wallindustries.com</a>
Web:	<a href="http://www.wallindustries.com">www.wallindustries.com</a>
Address:	37 Industrial Drive Exeter, NH 03833