

Product Preview

Intelligent Dynamic Clock Switch (IDCS) PLL Clock Driver

The MPC99J93 is a PLL clock driver designed specifically for redundant clock tree designs. The device receives two differential LVPECL clock signals from which it generates 5 new differential LVPECL clock outputs. Two of the output pairs regenerate the input signals frequency and phase while the other three pairs generate 2x, phase aligned clock outputs.

Features:

- Fully Integrated PLL
- Intelligent Dynamic Clock Switch
- LVPECL Clock Outputs
- LVCMOS Control I/O
- 3.3V Operation
- 32-Lead LQFP Packaging

Functional Description

The MPC99J93 Intelligent Dynamic Clock Switch (IDCS) circuit continuously monitors both input CLK signals. Upon detection of a failure (CLK stuck HIGH or LOW for at least 1 period), the INP_BAD for that CLK will be latched (H). If that CLK is the primary clock, the IDCS will switch to the good secondary clock and phase/frequency alignment will occur with minimal output phase disturbance. The typical phase bump caused by a failed clock is eliminated. (See Application Information section).

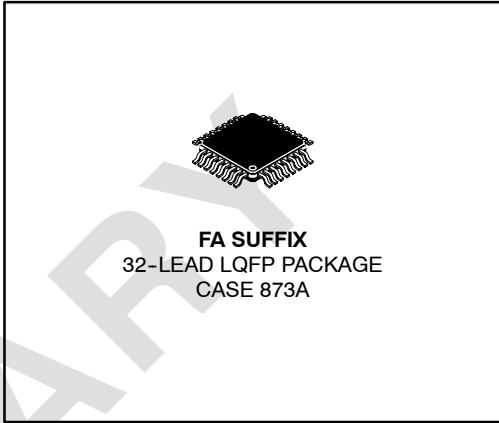

Freescale Semiconductor, Inc.

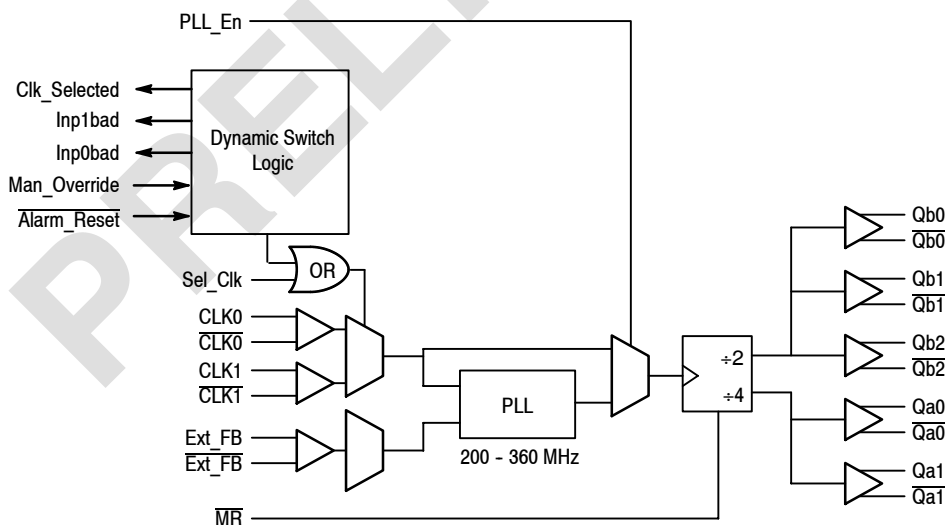

Figure 1. Block Diagram

This document contains information on a product under development. Motorola reserves the right to change or discontinue this product without notice.
© Motorola Inc. 2003

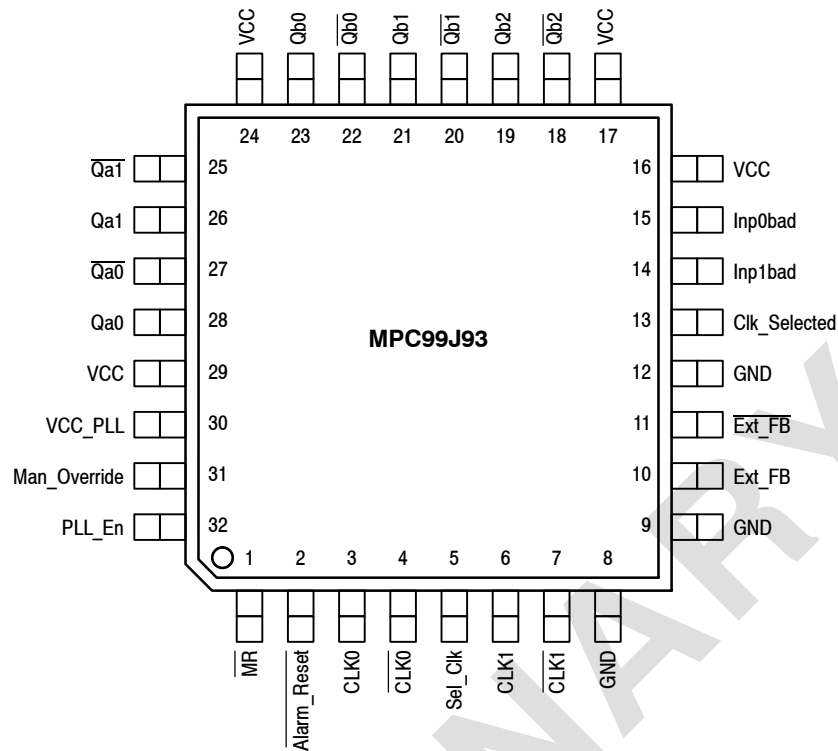

Figure 2. 32-Lead Pinout (Top View)

Table 1. Pin Descriptions

Pin Name	I/O	Pin Definition
CLK0, $\overline{\text{CLK0}}$ CLK1, $\overline{\text{CLK1}}$	LVPECL Input LVPECL Input	Differential PLL clock reference (CLK0 pulldown, $\overline{\text{CLK0}}$ pullup) Differential PLL clock reference (CLK1 pulldown, $\overline{\text{CLK1}}$ pullup)
Ext_FB, $\overline{\text{Ext_FB}}$	LVPECL Input	Differential PLL feedback clock (Ext_FB pulldown, $\overline{\text{Ext_FB}}$ pullup)
Qa0:1, $\overline{\text{Qa0:1}}$	LVPECL Output	Differential 1x output pairs. Connect one QAx pair to Ext_FB.
Qb0:2, $\overline{\text{Qb0:2}}$	LVPECL Output	Differential 2x output pairs
Inp0bad	LVC MOS Output	Indicates detection of a bad input reference clock 0 with respect to the feedback signal. The output is active HIGH and will remain HIGH until the alarm reset is asserted
Inp1bad	LVC MOS Output	Indicates detection of a bad input reference clock 1 with respect to the feedback signal. The output is active HIGH and will remain HIGH until the alarm reset is asserted
Clk_Selected	LVC MOS Output	'0' if clock 0 is selected, '1' if clock 1 is selected
Alarm_Reset	LVC MOS Input	'0' will reset the input bad flags and align Clk_Selected with Sel_Clk. The input is "one-shotted" (50k Ω pullup)
Sel_Clk	LVC MOS Input	'0' selects CLK0, '1' selects CLK1 (50k Ω pulldown)
Manual_Override	LVC MOS Input	'1' disables internal clock switch circuitry (50k Ω pulldown)
PLL_En	LVC MOS Input	'0' bypasses selected input reference around the phase-locked loop (50k Ω pullup)
MR	LVC MOS Input	'0' resets the internal dividers forcing Q outputs LOW. Asynchronous to the clock (50k Ω pullup)
VCCA	Power Supply	PLL power supply
VCC	Power Supply	Digital power supply
GND A	Power Supply	PLL ground
GND	Power Supply	Digital ground

Table 2. ABSOLUTE MAXIMUM RATINGS^a

Symbol	Characteristics	Min	Max	Unit	Condition
V _{CC}	Supply Voltage	-0.3	3.9	V	
V _{IN}	DC Input Voltage	-0.3	V _{CC} +0.3	V	
V _{OUT}	DC Output Voltage	-0.3	V _{CC} +0.3	V	
I _{IN}	DC Input Current		±20	mA	
I _{OUT}	DC Output Current		±50	mA	
T _S	Storage temperature	-65	125	°C	

a. Absolute maximum continuous ratings are those maximum values beyond which damage to the device may occur. Exposure to these conditions or conditions beyond those indicated may adversely affect device reliability. Functional operation at absolute-maximum-rated conditions is not implied.

Table 3. GENERAL SPECIFICATIONS

Symbol	Characteristics	Min	Typ	Max	Unit	Condition
V _{TT}	Output termination voltage		V _{CC} - 2		V	
MM	ESD Protection (Machine model)	175			V	
HBM	ESD Protection (Human body model)	1500			V	
CDM	ESD Protection (Charged device model)	1000			V	
LU	Latch-up immunity	100			mA	
C _{IN}	Input Capacitance		4.0		pF	Inputs
θ _{JA}	Thermal resistance junction to ambient JESD 51-3, single layer test board		83.1	86.0	°C/W	Natural convection
			73.3	75.4	°C/W	100 ft/min
			68.9	70.9	°C/W	200 ft/min
			63.8	65.3	°C/W	400 ft/min
			57.4	59.6	°C/W	800 ft/min
	JESD 51-6, 2S2P multilayer test board		59.0	60.6	°C/W	Natural convection
			54.4	55.7	°C/W	100 ft/min
			52.5	53.8	°C/W	200 ft/min
			50.4	51.5	°C/W	400 ft/min
			47.8	48.8	°C/W	800 ft/min
θ _{JC}	Thermal resistance junction to case		23.0	26.3	°C/W	MIL-SPEC 883E Method 1012.1
T _J	Operating junction temperature ^a (continuous operation) MTBF = 9.1 years			110	°C	

a. Operating junction temperature impacts device life time. Maximum continuous operating junction temperature should be selected according to the application life time requirements (See application note AN1545 for more information). The device AC and DC parameters are specified up to 110°C junction temperature allowing the MPC99J93 to be used in applications requiring industrial temperature range. It is recommended that users of the MPC99J93 employ thermal modeling analysis to assist in applying the junction temperature specifications to their particular application.

Freescale Semiconductor, Inc.

Table 4. DC CHARACTERISTICS ($V_{CC} = 3.3V \pm 5\%$, $T_A = -40^\circ$ to $+85^\circ C$)

Symbol	Characteristics	Min	Typ	Max	Unit	Condition
LVCMOS control inputs (MR, PLL_En, Sel_Clk, Man_Override, Alarm_Reset)						
V_{IH}	Input High Voltage	2.0		$V_{CC} + 0.3$	V	
V_{IL}	Input Low Voltage			0.8	V	
I_{IN}	Input Current ^a			± 100	μA	$V_{IN} = V_{CC}$ or GND
LVCMOS control outputs (Clk_selected, Inp0bad, Inp1bad)						
V_{OH}	Output High Voltage	2.0			V	$I_{OH} = -24$ mA
V_{OL}	Output Low Voltage			0.55	V	$I_{OL} = 24$ mA
LVPECL clock inputs (CLK0, CLK1, Ext_FB) ^b						
V_{PP}	DC Differential Input Voltage ^c	0.1		1.3	V	Differential operation
V_{CMR}	Differential Cross Point Voltage ^d	$V_{CC} - 1.8$		$V_{CC} - 0.3$	V	Differential operation
I_{IN}	Input Current ^a			± 100	μA	$V_{IN} = V_{CC}$ or GND
LVPECL clock outputs (QA[1:0], QB[2:0])						
V_{OH}	Output High Voltage	$V_{CC} - 1.20$	$V_{CC} - 0.95$	$V_{CC} - 0.70$	V	Termination 50Ω to V_{TT}
V_{OL}	Output Low Voltage	$V_{CC} - 1.90$	$V_{CC} - 1.75$	$V_{CC} - 1.45$	V	Termination 50Ω to V_{TT}
Supply Current						
I_{GND}	Maximum Power Supply Current			180	mA	GND pins
I_{CC_PLL}	Maximum PLL Supply Current			15	mA	V_{CC_PLL} pin

- a. Inputs have internal pull-up/pull-down resistors affecting the input current.
- b. Clock inputs driven by differential LVPECL compatible signals.
- c. V_{PP} is the minimum differential input voltage swing required to maintain AC characteristics.
- d. V_{CMR} (DC) is the crosspoint of the differential input signal. Functional operation is obtained when the crosspoint is within the V_{CMR} (DC) range and the input swing lies within the V_{PP} (DC) specification.

Table 5. AC Characteristics ($V_{CC} = 3.3V \pm 5\%$, $T_A = -40^{\circ}C$ to $+85^{\circ}C$)^a

Symbol	Characteristics	Min	Typ	Max	Unit	Condition
f_{ref}	Input Reference Frequency +4 feedback	50		90	MHz	PLL locked
f_{VCO}	VCO Frequency Range ^b +4 feedback	200		360	MHz	
f_{MAX}	Output Frequency QA[1:0] QB[2:0]	50 100		90 180	MHz MHz	PLL locked
f_{refDC}	Reference Input Duty Cycle	25		75	%	
t_{ϕ}	Propagation Delay SPO, static phase offset ^c CLK0, CLK1 to any Q	-0.15 0.9		+0.17 1.8	ns ns	PLL_EN=1 PLL_EN=0
V_{PP}	Differential input voltage ^d (peak-to-peak)	0.25		1.3	V	
V_{CMR}	Differential input crosspoint voltage ^e	$V_{CC}-1.7$		$V_{CC}-0.3$	V	
$t_{sk(O)}$	Output-to-output Skew within QA[2:0] or QB[1:0] within device			50 80	ps ps	
$\Delta_{per/cycle}$	Rate of change of period QA[1:0] ^f QB[2:0] ^f QA[1:0] ^g QB[2:0] ^g		20 10 200 100	50 25 400 200	ps ps ps ps	
DC	Output Duty Cycle	45	50	55	%	
$t_{JIT(CC)}$	Cycle-to-Cycle Jitter RMS (1 σ)		25		ps	
t_{LOCK}	Maximum PLL Lock Time			10	ms	
t_r, t_f	Output Rise/Fall Time	0.05		0.70	ns	20% to 80%

- a. AC characteristics apply for parallel output termination of 50Ω to $V_{CC} - 2V$.
- b. The input reference frequency must match the VCO lock range divided by the feedback divider ratio (FB): $f_{ref} = f_{VCO} \div FB$.
- c. CLK0, CLK1 to Ext_FB.
- d. V_{PP} is the minimum differential input voltage swing required to maintain AC characteristics including SPO and device-to-device skew. Applicable to CLK0, CLK1 and Ext_FB.
- e. V_{CMR} (AC) is the crosspoint of the differential input signal. Normal AC operation is obtained when the crosspoint is within the V_{CMR} (AC) range and the input swing lies within the V_{PP} (AC) specification. Violation of V_{CMR} (AC) or V_{PP} (AC) impacts the SPO, device and part-to-part skew. Applicable to CLK0, CLK1 and Ext_FB.
- f. Specification holds for a clock switch between two input signals (CLK0, CLK1) no greater than 400 ps out of phase. Delta period change per cycle is averaged over the clock switch excursion.
- g. Specification holds for a clock switch between two input signals (CLK0, CLK1) at any phase difference ($\pm 180^{\circ}$). Delta period change per cycle is averaged over the clock switch excursion.

Freescale Semiconductor, Inc.

PRELIMINARY

APPLICATIONS INFORMATION

The MPC99J93 is a dual clock PLL with on-chip Intelligent Dynamic Clock Switch (IDCS) circuitry.

Definitions

primary clock: The input CLK selected by Sel_Clk.

secondary clock: The input CLK NOT selected by Sel_Clk.

PLL reference signal: The CLK selected as the PLL reference signal by Sel_Clk or IDCS. (IDCS can override Sel_Clk).

Status Functions

Clk_Selected: Clk_Selected (L) indicates CLK0 is selected as the PLL reference signal. Clk_Selected (H) indicates CLK1 is selected as the PLL reference signal.

INP_BAD: Latched (H) when it's CLK is stuck (H) or (L) for at least one Ext_FB period (Pos to Pos or Neg to Neg). Cleared (L) on assertion of Alarm_Reset.

Control Functions

Sel_Clk: Sel_Clk (L) selects CLK0 as the primary clock. Sel_Clk (H) selects CLK1 as the primary clock.

Alarm_Reset: Asserted by a negative edge. Generates a one-shot reset pulse that clears INPUT_BAD latches and Clk_Selected latch.

PLL_En: While (L), the PLL reference signal is substituted for the VCO output.

MR: While (L), internal dividers are held in reset which holds all Q outputs LOW.

Man Override (H)

(IDCS is disabled, PLL functions normally). PLL reference signal (as indicated by Clk_Selected) will always be the CLK selected by Sel_Clk. The status function INP_BAD is active in Man Override (H) and (L).

Man Override (L)

(IDCS is enabled, PLL functions enhanced). The first CLK to fail will latch it's INP_BAD (H) status flag and select the other input as the Clk_Selected for the PLL reference clock. Once latched, the Clk_Selected and INP_BAD remain latched until assertion of Alarm_Reset which clears all latches (INP_BADs are cleared and Clk_Selected = Sel_Clk). NOTE: If both CLKs are bad when Alarm_Reset is asserted, both INP_BADs will be latched (H) after one Ext_FB period and Clk_Selected will be

latched (L) indicating CLK0 is the PLL reference signal. While neither INP_BAD is latched (H), the Clk_Selected can be freely changed with Sel_Clk. Whenever a CLK switch occurs, (manually or by IDCS), following the next negative edge of the newly selected PLL reference signal, the next positive edge pair of Ext_FB and the newly selected PLL reference signal will slew to alignment.

To calculate the overall uncertainty between the input CLKs and the outputs from multiple MPC99J93's, the following procedure should be used. Assuming that the input CLKs to all MPC99J93's are exactly in phase, the total uncertainty will be the sum of the static phase offset, max I/O jitter, and output to output skew.

During a dynamic switch, the output phase between two devices may be increased for a short period of time. If the two input CLKs are 400ps out of phase, a dynamic switch of an MPC99J93 will result in an instantaneous phase change of 400ps to the PLL reference signal without a corresponding change in the output phase (due to the limited response of the PLL). As a result, the I/O phase of a device, undergoing this switch, will initially be 400ps and diminish as the PLL slews to its new phase alignment. This transient timing issue should be considered when analyzing the overall skew budget of a system.

Hot insertion and withdrawal

In PECL applications, a powered up driver will experience a low impedance path through an MPC99J93 input to its powered down VCC pins. In this case, a 100 ohm series resistance should be used in front of the input pins to limit the driver current. The resistor will have minimal impact on the rise and fall times of the input signals.

Acquiring Frequency Lock

1. While the MPC99J93 is receiving a valid CLK signal, assert Man_Override HIGH.
2. The PLL will phase and frequency lock within the specified lock time.
3. Apply a HIGH to LOW transition to Alarm_Reset to reset Input Bad flags.
4. De-assert Man_Override LOW to enable Intelligent Dynamic Clock Switch mode.

OUTLINE DIMENSIONS

FA SUFFIX
PLASTIC LQFP PACKAGE
CASE 873A-03
ISSUE B

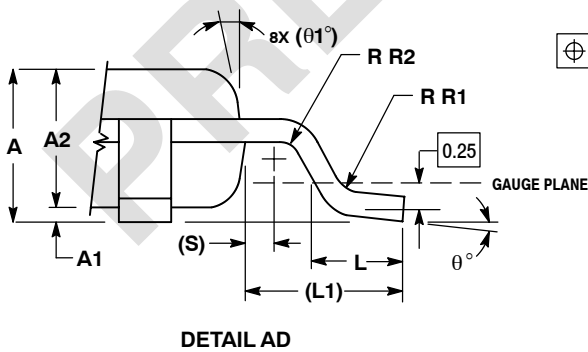
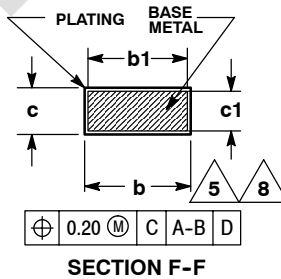
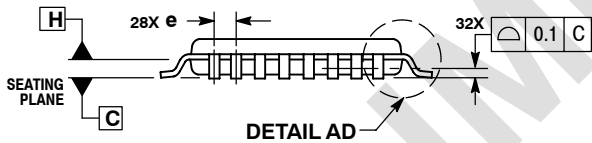
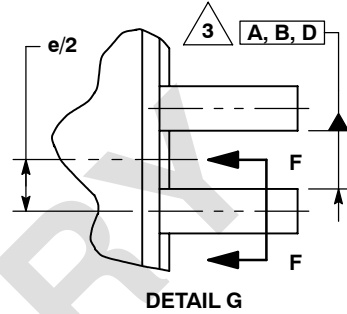
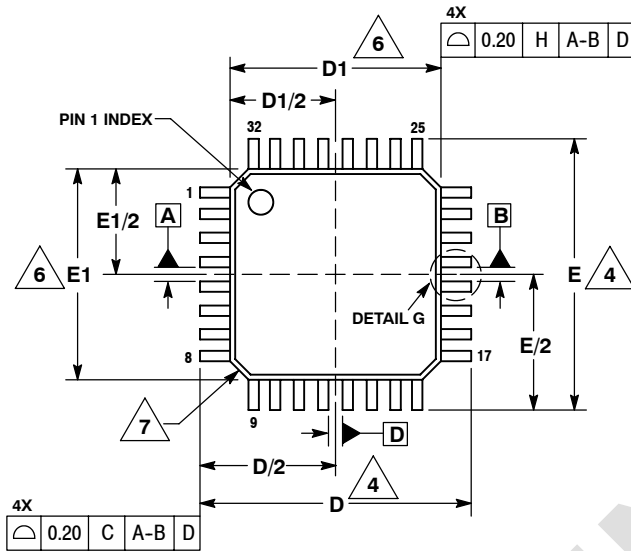

NOTES:

1. DIMENSIONS ARE IN MILLIMETERS.
2. INTERPRET DIMENSIONS AND TOLERANCES PER ASME Y14.5M, 1994.
3. DATUMS A, B, AND D TO BE DETERMINED AT DATUM PLANE H.
4. DIMENSIONS D AND E TO BE DETERMINED AT SEATING PLANE C.
5. DIMENSION b DOES NOT INCLUDE DAMBAR PROTRUSION. ALLOWABLE DAMBAR PROTRUSION SHALL NOT CAUSE THE LEAD WIDTH TO EXCEED THE MAXIMUM b DIMENSION BY MORE THAN 0.08-mm. DAMBAR CANNOT BE LOCATED ON THE LOWER RADIUS OR THE FOOT. MINIMUM SPACE BETWEEN PROTRUSION AND ADJACENT LEAD OR PROTRUSION: 0.07-mm.
6. DIMENSIONS D1 AND E1 DO NOT INCLUDE MOLD PROTRUSION. ALLOWABLE PROTRUSION IS 0.25-mm PER SIDE. D1 AND E1 ARE MAXIMUM PLASTIC BODY SIZE DIMENSIONS INCLUDING MOLD MISMATCH.
7. EXACT SHAPE OF EACH CORNER IS OPTIONAL.
8. THESE DIMENSIONS APPLY TO THE FLAT SECTION OF THE LEAD BETWEEN 0.1-mm AND 0.25-mm FROM THE LEAD TIP.

DIM	MILLIMETERS	
	MIN	MAX
A	1.40	1.60
A1	0.05	0.15
A2	1.35	1.45
b	0.30	0.45
b1	0.30	0.40
c	0.09	0.20
c1	0.09	0.16
D	9.00 BSC	
D1	7.00 BSC	
e	0.80 BSC	
E	9.00 BSC	
E1	7.00 BSC	
L	0.50	0.70
L1	1.00 REF	
θ	0°	7°
θ1	12° REF	
R1	0.08	0.20
R2	---	
S	0.20 REF	

PRELIMINARY

Information in this document is provided solely to enable system and software implementers to use Motorola products. There are no express or implied copyright licenses granted hereunder to design or fabricate any integrated circuits or integrated circuits based on the information in this document.

Motorola reserves the right to make changes without further notice to any products herein. Motorola makes no warranty, representation or guarantee regarding the suitability of its products for any particular purpose, nor does Motorola assume any liability arising out of the application or use of any product or circuit, and specifically disclaims any and all liability, including without limitation consequential or incidental damages. "Typical" parameters that may be provided in Motorola data sheets and/or specifications can and do vary in different applications and actual performance may vary over time. All operating parameters, including "Typicals", must be validated for each customer application by customer's technical experts. Motorola does not convey any license under its patent rights nor the rights of others. Motorola products are not designed, intended, or authorized for use as components in systems intended for surgical implant into the body, or other applications intended to support or sustain life, or for any other application in which the failure of the Motorola product could create a situation where personal injury or death may occur. Should Buyer purchase or use Motorola products for any such unintended or unauthorized application, Buyer shall indemnify and hold Motorola and its officers, employees, subsidiaries, affiliates, and distributors harmless against all claims, costs, damages, and expenses, and reasonable attorney fees arising out of, directly or indirectly, any claim of personal injury or death associated with such unintended or unauthorized use, even if such claim alleges that Motorola was negligent regarding the design or manufacture of the part.

MOTOROLA and the Stylized M Logo are registered in the US Patent and Trademark Office. All other product or service names are the property of their respective owners. Motorola, Inc. is an Equal Opportunity/Affirmative Action Employer.

© Motorola Inc. 2003

HOW TO REACH US:

USA/EUROPE/LOCATIONS NOT LISTED:

Motorola Literature Distribution
P.O. Box 5405, Denver, Colorado 80217
1-800-521-6274 or 480-768-2130

JAPAN: Motorola Japan Ltd.; SPS, Technical Information Center,
3-20-1, Minami-Azabu, Minato-ku, Tokyo 106-8573, Japan
81-3-3440-3569

ASIA/PACIFIC: Motorola Semiconductors H.K. Ltd.; Silicon Harbour Centre,
2 Dai King Street, Tai Po Industrial Estate, Tai Po, N.T., Hong Kong
852-26668334

HOME PAGE: <http://motorola.com/semiconductors>



◇
**For More Information On This Product,
Go to: www.freescale.com**

MPC99J93/D